

**WORLD-CLASS
GARAGE TOOLS & EQUIPMENTS
LATEST . STURDY . INNOVATIVE**

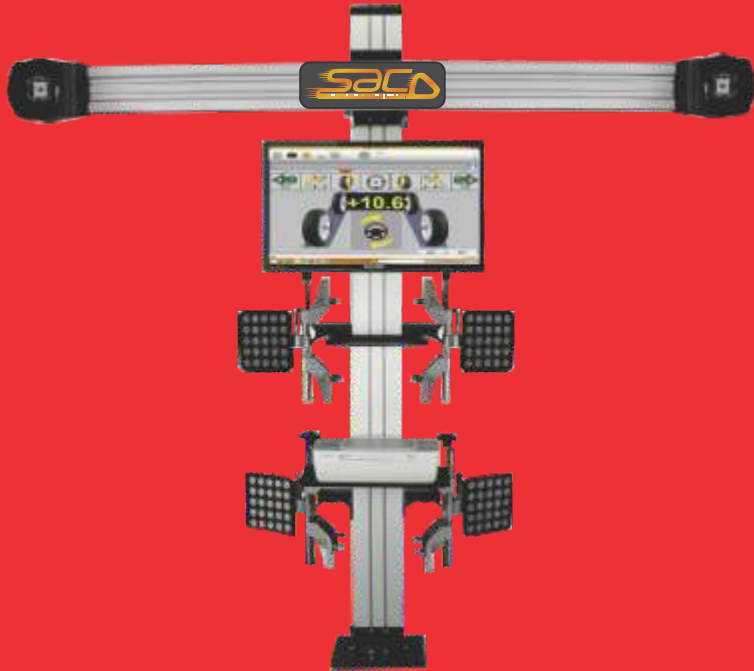

Xcent Eco



Efficient · Transparent · Inclusive

CATALOGUE

About us



Mr. S.K. Yadav
Director

We wish to introduce ourselves as a company with innovative technological products suitable for the Indian work environment. Our machines are designed ergonomically, reliable, affordable, low maintenance and highly accurate imported from Germany, Italy, U.K., Taiwan, Korea and China and assembled in India.

With vast 21 years experience in Automobile Garage industry we wish to offer our experience to design, modernize your workshop with latest, sturdy and innovative tools and equipment's, to get maximum yield from your workshop in terms of customer satisfaction, technician friendly and low maintenance.

We are offering complete range of tools & equipment's to all your needs in washing center, shop floor, diagnostic and body shop.

RELIABILITY & SAFETY should be your first consideration when you look for workshop machinery. SKYTECH tools and equipment's are designed for use by professionals. They deliver hours of dependable use, with less time spent for breakdown and calibration issues.

SALCO tools and equipment's are built to last and to withstand tough day-to-day usage-incorporating highest quality components, built in electrical overload protection systems and rugged construction.

SALCO has a proven record of offering products which have surpassed industry standard certification such as MSME UDYAM registration, ISO 9001:2015 Quality Assurance Certification. Our quality, reputation, service & credibility has endowed on us the praise of our peers in the tyre and vehicle Industry.

Quality is the job of every team member in the plant, from careful inspection of parts and raw materials at receiving to packing the finished product. It's our mission to deliver a product that will be perfect out of the box and deliver years of reliable service.

Certificates

| UDYAM REGISTRATION CERTIFICATE | | | | | | | | | | | | | | | | | | | | | | | | | | | | | | | | | | | | | | | | | | | | | | | | |
|----------------------------------------------------|---------------------------------------------------------------------------------------------------------------------------------------------------------------------------------------------------------------------------------------------------------------------------------------------------------------------------------------------------------------------------------------------------------------------------------------------------------------------------------------------------------------------------------------------------------------------------------------------------------------------------------------------------------------------------------------------------------------------------------------------------------------------------------------------------------------------------------------------------------------------------------------------------------------------------------------------------------------------------------------------------------------------------------------------------------------------------------------------------------------------------------------------------------------------------------------------------------------------------------------------------------------------------------------------------------------------------------|---------------------------------------------------------------------------|------------------------------------------------------------------------------------------------------------------------------------------------------------------------|---------------------------|---------------|----------------------------|----------------------|----------|--------------|----------------------------------------------------|-----------------------------------------------------------------|--------------------------------------------------------------------------------|---------------|------------------|----------------------------------------------------|-----------------------------------------------------------------------|------------------------------------------------------------------------------------------------------------------------------------------------------------------------|---------------|-------|----------------------------------------------------------------|---------------------------------------------------------------------------|--------------------------------------------------------------------|----------|------|---------------------------------------------------------------------------------------|---------------------------------------------------------|--|----------|-------|-------|--|--|--|-----------------|--------|--|--|--|--------|-----------|--|--|--|-------|--|--|--|---------------------------|
| UDYAM REGISTRATION NUMBER | UDYAM-DL-06-0022667 | | | | | | | | | | | | | | | | | | | | | | | | | | | | | | | | | | | | | | | | | | | | | | | |
| NAME OF ENTERPRISE | SKYTECH AUTOEQUIP CO | | | | | | | | | | | | | | | | | | | | | | | | | | | | | | | | | | | | | | | | | | | | | | | |
| TYPE OF ENTERPRISE* | MICRO | | | | | | | | | | | | | | | | | | | | | | | | | | | | | | | | | | | | | | | | | | | | | | | |
| MAJOR ACTIVITY | SERVICES | | | | | | | | | | | | | | | | | | | | | | | | | | | | | | | | | | | | | | | | | | | | | | | |
| SOCIAL CATEGORY OF ENTREPRENEUR | OBC | | | | | | | | | | | | | | | | | | | | | | | | | | | | | | | | | | | | | | | | | | | | | | | |
| NAME OF UNITS | <table border="1"> <thead> <tr> <th>S.No.</th> <th>NAME OF UNITS</th> </tr> </thead> <tbody> <tr> <td>1.</td> <td>SKYTECH AUTOEQUIP CO</td> </tr> </tbody> </table> | | | S.No. | NAME OF UNITS | 1. | SKYTECH AUTOEQUIP CO | | | | | | | | | | | | | | | | | | | | | | | | | | | | | | | | | | | | | | | | | |
| S.No. | NAME OF UNITS | | | | | | | | | | | | | | | | | | | | | | | | | | | | | | | | | | | | | | | | | | | | | | | |
| 1. | SKYTECH AUTOEQUIP CO | | | | | | | | | | | | | | | | | | | | | | | | | | | | | | | | | | | | | | | | | | | | | | | |
| OFFICIAL ADDRESS OF ENTERPRISE | <table border="1"> <thead> <tr> <th>Field/Block No.</th> <th>HOUSE NO-40</th> <th>Name of Premises/ Building</th> <th>Block</th> <th>BLOCK-A</th> </tr> </thead> <tbody> <tr> <td>Village/Town</td> <td>Dohi</td> <td></td> <td></td> <td></td> </tr> <tr> <td>Road/Street/Lane</td> <td>EXTN JAIN NAGAR, KARALA</td> <td></td> <td></td> <td></td> </tr> <tr> <td>State</td> <td>DELHI</td> <td></td> <td></td> <td></td> </tr> <tr> <td>City</td> <td></td> <td></td> <td></td> <td></td> </tr> <tr> <td>State</td> <td>DELHI</td> <td></td> <td></td> <td></td> </tr> <tr> <td>North West, Pin</td> <td>110081</td> <td></td> <td></td> <td></td> </tr> <tr> <td>Mobile</td> <td>044728021</td> <td></td> <td></td> <td></td> </tr> <tr> <td>Email</td> <td></td> <td></td> <td></td> <td>info@skytechautoequip.com</td> </tr> </tbody> </table> | | | Field/Block No. | HOUSE NO-40 | Name of Premises/ Building | Block | BLOCK-A | Village/Town | Dohi | | | | Road/Street/Lane | EXTN JAIN NAGAR, KARALA | | | | State | DELHI | | | | City | | | | | State | DELHI | | | | North West, Pin | 110081 | | | | Mobile | 044728021 | | | | Email | | | | info@skytechautoequip.com |
| Field/Block No. | HOUSE NO-40 | Name of Premises/ Building | Block | BLOCK-A | | | | | | | | | | | | | | | | | | | | | | | | | | | | | | | | | | | | | | | | | | | | |
| Village/Town | Dohi | | | | | | | | | | | | | | | | | | | | | | | | | | | | | | | | | | | | | | | | | | | | | | | |
| Road/Street/Lane | EXTN JAIN NAGAR, KARALA | | | | | | | | | | | | | | | | | | | | | | | | | | | | | | | | | | | | | | | | | | | | | | | |
| State | DELHI | | | | | | | | | | | | | | | | | | | | | | | | | | | | | | | | | | | | | | | | | | | | | | | |
| City | | | | | | | | | | | | | | | | | | | | | | | | | | | | | | | | | | | | | | | | | | | | | | | | |
| State | DELHI | | | | | | | | | | | | | | | | | | | | | | | | | | | | | | | | | | | | | | | | | | | | | | | |
| North West, Pin | 110081 | | | | | | | | | | | | | | | | | | | | | | | | | | | | | | | | | | | | | | | | | | | | | | | |
| Mobile | 044728021 | | | | | | | | | | | | | | | | | | | | | | | | | | | | | | | | | | | | | | | | | | | | | | | |
| Email | | | | info@skytechautoequip.com | | | | | | | | | | | | | | | | | | | | | | | | | | | | | | | | | | | | | | | | | | | | |
| DATE OF INCORPORATION / REGISTRATION OF ENTERPRISE | 26/07/2021 | | | | | | | | | | | | | | | | | | | | | | | | | | | | | | | | | | | | | | | | | | | | | | | |
| DATE OF COMMENCEMENT OF PRODUCTION/BUSINESS | 15/09/2015 | | | | | | | | | | | | | | | | | | | | | | | | | | | | | | | | | | | | | | | | | | | | | | | |
| NATIONAL INDUSTRY CLASSIFICATION CODE(S) | <table border="1"> <thead> <tr> <th>S.No.</th> <th>NIC 4 Digit</th> <th>NIC 4 Digit</th> <th>NIC 4 Digit</th> <th>Activity</th> </tr> </thead> <tbody> <tr> <td>1.</td> <td>28 - Manufacture of machinery and equipment n.e.c.</td> <td>2822 - Manufacture of metal-forming machinery and machine tools</td> <td>2823 - Manufacture of parts and accessories for the machine tools listed above</td> <td>Manufacturing</td> </tr> <tr> <td>2.</td> <td>28 - Manufacture of machinery and equipment n.e.c.</td> <td>2824 - Manufacture of machines for mining, quarrying and construction</td> <td>28243 - Manufacture of earth-moving machinery (bulldozers, angle-dozers, graders, scrapers, scrapers, mechanical shears, shovel loaders, off-road dumping trucks etc.)</td> <td>Manufacturing</td> </tr> <tr> <td>3.</td> <td>46 - Wholesale trade, except of motor vehicles and motorcycles</td> <td>4652 - Wholesale of electronic and telecommunications equipment and parts</td> <td>46529 - Wholesale of other electronic equipments and parts thereof</td> <td>Services</td> </tr> <tr> <td>4.</td> <td>82 - Other administrative office support and other business support activities n.e.c.</td> <td>8299 - Other business support service activities n.e.c.</td> <td></td> <td>Services</td> </tr> </tbody> </table> | | | S.No. | NIC 4 Digit | NIC 4 Digit | NIC 4 Digit | Activity | 1. | 28 - Manufacture of machinery and equipment n.e.c. | 2822 - Manufacture of metal-forming machinery and machine tools | 2823 - Manufacture of parts and accessories for the machine tools listed above | Manufacturing | 2. | 28 - Manufacture of machinery and equipment n.e.c. | 2824 - Manufacture of machines for mining, quarrying and construction | 28243 - Manufacture of earth-moving machinery (bulldozers, angle-dozers, graders, scrapers, scrapers, mechanical shears, shovel loaders, off-road dumping trucks etc.) | Manufacturing | 3. | 46 - Wholesale trade, except of motor vehicles and motorcycles | 4652 - Wholesale of electronic and telecommunications equipment and parts | 46529 - Wholesale of other electronic equipments and parts thereof | Services | 4. | 82 - Other administrative office support and other business support activities n.e.c. | 8299 - Other business support service activities n.e.c. | | Services | | | | | | | | | | | | | | | | | | | | |
| S.No. | NIC 4 Digit | NIC 4 Digit | NIC 4 Digit | Activity | | | | | | | | | | | | | | | | | | | | | | | | | | | | | | | | | | | | | | | | | | | | |
| 1. | 28 - Manufacture of machinery and equipment n.e.c. | 2822 - Manufacture of metal-forming machinery and machine tools | 2823 - Manufacture of parts and accessories for the machine tools listed above | Manufacturing | | | | | | | | | | | | | | | | | | | | | | | | | | | | | | | | | | | | | | | | | | | | |
| 2. | 28 - Manufacture of machinery and equipment n.e.c. | 2824 - Manufacture of machines for mining, quarrying and construction | 28243 - Manufacture of earth-moving machinery (bulldozers, angle-dozers, graders, scrapers, scrapers, mechanical shears, shovel loaders, off-road dumping trucks etc.) | Manufacturing | | | | | | | | | | | | | | | | | | | | | | | | | | | | | | | | | | | | | | | | | | | | |
| 3. | 46 - Wholesale trade, except of motor vehicles and motorcycles | 4652 - Wholesale of electronic and telecommunications equipment and parts | 46529 - Wholesale of other electronic equipments and parts thereof | Services | | | | | | | | | | | | | | | | | | | | | | | | | | | | | | | | | | | | | | | | | | | | |
| 4. | 82 - Other administrative office support and other business support activities n.e.c. | 8299 - Other business support service activities n.e.c. | | Services | | | | | | | | | | | | | | | | | | | | | | | | | | | | | | | | | | | | | | | | | | | | |
| DATE OF UDYAM REGISTRATION | 27/07/2021 | | | | | | | | | | | | | | | | | | | | | | | | | | | | | | | | | | | | | | | | | | | | | | | |

| Certificate of Registration | |
|-----------------------------------------------------------------------------------------------------------------------------------------------------------------------------------------------------------------------------------------------------------|--------------|
| This is to Certify that Quality Management System of | |
| SKYTECH AUTOEQUIP CO | |
| HOUSE NO-40, BLOCK-A, EXTN JAIN NAGAR, KARALA, NORTH WEST DELHI, DELHI-110081, INDIA. | |
| has been assessed and found to conform to the requirements of ISO 9001:2015 for the following scope: | |
| DEALING IN AUTOMOBILE WORKSHOP TOOLS AND EQUIPMENTS, INVOLVED IN MANUFACTURING, TRADING AND SERVICING OF MECHANICAL, ELECTRONIC AND HYDRAULIC EQUIPMENTS. | |
| Certificate No | : 21EQD074 |
| Initial Registration Date | : 04/08/2021 |
| Date of Expiry | : 03/08/2024 |
| 1st Surve. Due | : 04/07/2022 |
| 2nd Surve. Due | : 04/07/2023 |
| | |
| Magnitude Management Services Pvt. Ltd 10/1, Manishkumar Building, 3C, Sector Phase, New Delhi-110029, India e-mail: info@mmms.com, delhi@mmms.com, website: www.mmms.com *Member of International Federation of Quality Assurance (IFQA) | |
| Director | |

MSME
UDYAM Registration Certificate

SKYTECH AUTOEQUIP CO. IS
ISO 9001:2015
Certificate Company

Index

Wheel Alignment Equipment



01-02

Tyre Care Equipment



27-27

Wheel Balancing Equipment



03-03

Pneumatic Equipment



28-29

Tyre Changer Equipment



04-05

Oil and Lube Equipment



30-30

Tyre Care Equipment



05-06

Body Shop Equipment



31-33

Lifting Equipment



07-12

Work Shop Special Tools



34-35

Washing Equipment



13-18

Tyre Inflators



36-36

Diagnostic Equipment



19-25

Garage Tools



37-38

Tyre Repair Tools & Equipment



26-26

Mobile Service Van



39-39

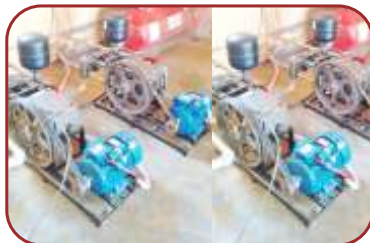

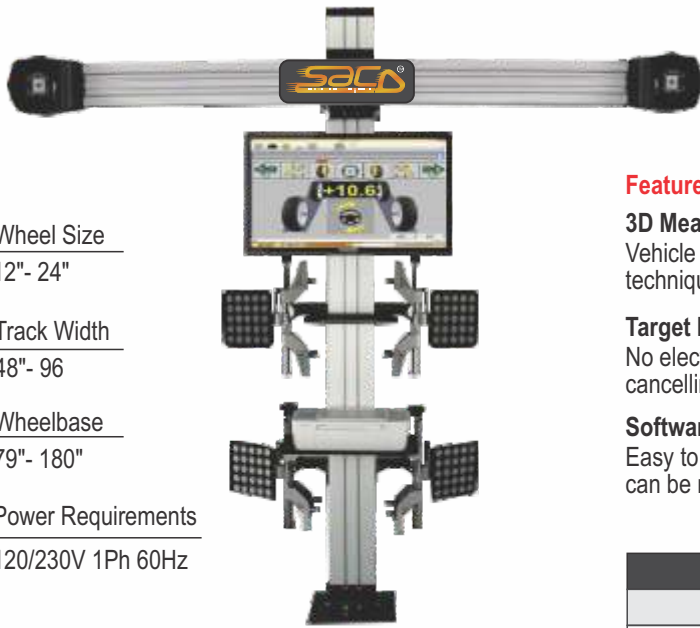

Wheel Size
12" - 24"

Track Width
48" - 96"

Wheelbase
79" - 180"

Power Requirements
120/230V 1Ph 60Hz

Xcent Eco

3D Computerised Wheel Alignment Machine

Features :-

3D Measuring Technique

Vehicle body foundations measuring technique, more accurate, more stable.

Target Plate

No electronic components, displacing the traditional electronic measuring head, cancelling the equipment failure caused by circuit.

Software System

Easy to operate, wheel alignment data can be read in two minutes.

Camera Measuring Technique

Double camera unite with 4 target plate, initiate revolutionary measuring method.

Maintenance

Maintenance is simple and easy, build-in one-click restore system, free software upgrade

| | Technical Data | |
|---------------------|----------------|----------|
| | Measurement | Accuracy |
| Display Accuracy | - | ± 0.01° |
| Camber | ± 10° | ± 0.02° |
| Caster | ± 20° | ± 0.06° |
| Kingpin Inclination | ± 20° | ± 0.06° |
| Toe-in & Toe-out | ± 20° | ± 0.02° |
| Set Back | ± 5° | ± 0.02° |
| Thrust Angle | ± 5° | ± 0.02° |

Optional Accessories

Printer - x1



Rear Slip Plates - x2



Xcent Pro

3D Computerised Wheel Alignment Machine



Xcent Pro

3D Computerised Wheel Alignment Machine with Auto Boom



Standard Accessories

High precision camera - x2



Target Plates front - x2, rear-x2



Wheel Clamps - x4



Mechanical Turntable - x2



Steering wheel lock - x1
Brake pedal lock - x1



Wheel Stopper - x2



Machine Suitable for Wheel Alignment on Scissor Lift & 4 Post Lift



Xcent CCD Machine

6x4 / 8x4

Features :-

Professional Machine

Professional high accuracy 6 meter wheel base, 8 toe sensors, fastest & stable data transfer, 24 inch clamps.

Backup

Calibration value backup in sensor heads.

Maintenance

Maintenance is simple and easy, build-in one-click restore system, free software upgrade

| | |
|--------------------|-------------------|
| Wheel Size | 12"- 24" |
| Track Width | 48"- 96" |
| Wheelbase | 79"- 180" |
| Power Requirements | 120/230V 1Ph 60Hz |

| Technical Data | | |
|---------------------------|-------------|----------|
| | Measurement | Accuracy |
| Toe | ±24° | ±1' |
| Camber | ±10° | ±1' |
| Caster | ±20° | ±2' |
| Steering Axle Inclination | ±20° | ±2' |
| Set Back | ±10° | ±1' |
| Thrust-Angle | ±10° | ±1' |

Xcent-Heavy

Truck/Bus Wheel Alignment

Features :-

Latest Technology

Simpler and more modern technology (most recent design compared to major competition) grants better reliability and less down-time for the end user.

LEDS

LEDS on the head inform the operator when adjustment angle is within specification range.

Bluetooth

Faster and more reliable data transmission through Bluetooth (radio can be a problem on large vehicles).

4 Remote Controls

Ability to operate the system from any head. Often you are far from the console and this slows down the operating speed.

- Significantly higher income production through superior efficiency
- Much faster operating times without any loss of accuracy
- Simpler system to learn, less training time involved



| Technical Data | | | Front Axle | Rear Axle |
|----------------|-------------|-------------------|------------|-----------|
| | Measurement | Total Measurement | Accuracy | Accuracy |
| Total toe | +/- 2° | +/- 5° | +/- 2' | +/- 2' |
| Partial toe | +/- 1° | +/- 2°30' | +/- 1' | +/- 1' |
| Set-back | +/- 2° | +/- 5° | +/- 2' | +/- 2' |
| Camber | +/- 3° | +/- 10° | +/- 2' | +/- 2' |
| Caster | +/- 10° | +/- 18° | +/- 5' | — |
| King pin | +/- 10° | +/- 18° | +/- 5' | — |
| Thrust angle | +/- 2° | +/- 5° | — | +/- 2' |

Blanc Eco

Computerised Digital Wheel Balancer

Features :-

- Seven segment display.
- 4 LED used for weight fitting position indication.
- High frequency buzzer provided for weights positions indication.
- Easy calibration using master weight.
- Auto breaking.
- Easy parameter setting.
- Automatic distance & Dia measurement.



| Technical Data | |
|--------------------|------------|
| Rim width | 1.5" - 10" |
| Rim Dia | 10" - 24" |
| Max Tyre Weight | 65 kg |
| Balancing Accuracy | ± 1 gram |
| Cycle Time | 7 seconds |
| RPM | 180 |
| Motor | 0.33Hp |
| Operating Voltage | 220V/50Hz |

Motorcycle Adaptor Kit (Optional)

Motorcycle Adaptor kit suitable for all Balancer models.



Code:WB-MT04

| Technical Data | |
|--------------------|------------|
| Rim width | 1.5" - 10" |
| Rim Dia | 10" - 24" |
| Max Tyre Weight | 75 kg |
| Balancing Accuracy | ± 1 gram |
| Cycle Time | 7 seconds |
| RPM | 180 |
| Motor | 0.33Hp |
| Operating Voltage | 220V/50Hz |

Blanc Pro

Computerised Digital Wheel Balancer Elevated Display

Features :-

- A wheel balancer with self-guaranteed ensured advancement.
- High accuracy fundamental shaft with strict heat treatment.
- Outfitted with protection hood, forceps, full set of cones and calipers.
- Split and weight concealing functions.
- Easy parameter setting.
- Automatic distance & Dia measurement.



Blanc Pro

Computerised Video Graphic Wheel Balancer

Features :-

- Video graphic display.
- 19" LED monitor for batter view.
- Easy calibration using master weight.
- High frequency buzzer provided for weights positions indication.
- Auto breaking.
- Easy parameter setting.
- Automatic distance & Dia measurement.
- PC membrane keypad for long life.



| Technical Data | |
|--------------------|------------|
| Rim width | 1.5" - 10" |
| Rim Dia | 10" - 24" |
| Max Tyre Weight | 75 kg |
| Balancing Accuracy | ± 1 gram |
| Cycle Time | 7 seconds |
| RPM | 180 |
| Motor | 0.33Hp |
| Operating Voltage | 220V/50Hz |

Blanc Heavy

Truck/Bus Wheel Balancer

Features :-

- Seven segment display.
- 4 LED used for weight fitting position indication.
- High frequency buzzer provided for weights positions indication.
- Easy calibration using



| Technical Data | |
|--------------------|------------|
| Rim width | 1.5" - 20" |
| Rim Dia | 10" - 24" |
| Max Tyre Weight | 200 kg |
| Balancing Accuracy | ± 50 gram |
| Cycle Time | 8 seconds |
| RPM | 150 |
| Motor | 0.4kw |
| Operating Voltage | 220V/50Hz |

Prism Eco

Semi Automatic Tyre Changer

Features :-

- Four sliding Jaws provides wider working scope.
- Swinging Arm with micro manipulator control knob for better adjustment between rim and demount tool.
- High-grade non-slip anti-scratch high-quality duck head, effective reduce the damage to the tyre rim.
- Capable of changing motorcycle tyres with additional adaptors.
- Pre filter and oil lubricator.
- Complete hardened plastic mounted head.



Prism Eco

Semi Automatic Tyre Changer

Features :-

- Four sliding Jaws provides wider working scope.
- Swinging Arm with micro manipulator control knob for better adjustment between rim and demount tool.
- High-grade non-slip anti-scratch high-quality duck head, effective reduce the damage to the tyre rim.
- Capable of changing motorcycle tyres with additional adaptors.
- Pre filter and oil lubricator.
- Complete hardened plastic mounted head.



Technical Data

| | |
|------------------------|------------------------|
| Rim clamping (outside) | 10" - 20" |
| Rim clamping (inside) | 12" - 22" |
| Rim Diameter | 1050 mm |
| Bead breaking force | 2800 kg |
| Rotation speed | 7 rpm |
| Motor | 1.1/0.75kw, 220V, 50Hz |
| Working Pressure | 6 to 8 Bar |

Motorcycle Adaptor Kit (Optional)

Motorcycle Adaptor kit suitable for all Tyre changer models.



Code:TC-MT04

Technical Data

| | |
|------------------------|------------------------|
| Rim clamping (outside) | 10" - 22" |
| Rim clamping (inside) | 12" - 24" |
| Rim Diameter | 1050 mm |
| Bead breaking force | 2800 kg |
| Rotation speed | 7 rpm |
| Motor | 1.1/0.75kw, 220V, 50Hz |
| Working Pressure | 6 to 8 Bar |

Prism Pro

Tilt Column Tyre Changer

Features :-

- Four sliding Jaws provides wider working scope.
- Equipped with high power motor, which increases tyre changer working efficiency.
- High-grade non-slip anti-scratch high-quality duck head, effective reduce the damage to the tyre rim.
- Capable of changing motorcycle tyres with additional adaptors.
- Pre filter and oil lubricator.
- Complete hardened plastic mounted head.



Prism Pro

Tilt Column Tyre Changer with Assist Arm

Features :-

- Automatic tyre changer, the tilt in reverse & forward of the column and the lock of the segment can be finished pneumatically.
- Apparatus head of extraordinary steel with the component of wear-obstruction.
- Auto-helper vertical post tilt back for easy adaptability.



Technical Data

| | |
|---------------------------|------------------------|
| Rim clamping from outside | 10" - 24" |
| Rim clamping from inside | 12" - 22" |
| Rim Diameter | 1000 mm |
| Bead breaking force | 2800 kg |
| Rotation speed | 7 rpm |
| Motor | 1.1/0.75kw, 220V, 50Hz |
| Working Pressure | 6 to 8 Bar |

Technical Data

| | |
|---------------------------|-------------------|
| Rim clamping from outside | 10" - 22" |
| Rim clamping from inside | 12" - 24" |
| Max. Wheel Diameter | 42" |
| Bead breaking force | 2800 kg |
| Rotation speed | 6-8 rpm |
| Motor | 1.5kw, 220V, 50Hz |
| Working Pressure | 8 to 10 Bar |

Prism Heavy — Truck/Bus Tyre Changer

Features :-

- Durable reduction gearbox
- High-efficiency motor
- Ease of use bead breaker disk & mounting tool
- Emergency switch
- Safely monitor all tyre changing operations
- Portable control console
- Lifting arm and universal chuck are all driven by the hydraulic pressure.
- Electrical control, move back and forth.

Operational Control (V)

24 V

Operating Pressure

130 Bar



Technical Data

| Model | Rim clamping capacity | Max Wheel Dia | Max Wheel Width | Bead breaking force | Max Tyre Weight | Hydraulic Pump Motor | Gearbox Motor |
|----------------------|-----------------------|---------------|-----------------|---------------------|-----------------|------------------------|----------------------------|
| Prism Heavy | 14" - 26" | 1600 mm (63") | 780 mm (30") | 2500 kg | 500 kg | 1.1KW, 3 Phase, 380V | 1.3 - 1.8KW, 3 Phase, 380V |
| Prism Heavy+ | 14" - 42" | 2300 mm (90") | 1050 mm (41") | 2500 kg | 1600 kg | 1.1KW, 3 Phase, 380V | 1.3 - 1.8KW, 3 Phase, 380V |
| Prism Heavy++ | 14" - 56" | 2300 mm (90") | 1065 mm (42") | 2690 kg | 1500 kg | 1.5Kw, 400V, 3PH, 50Hz | 1.5Kw, 400V, 3PH, 50Hz |

Tyre Care Equipment



SAC-30/50/75/100/150 —

Two Stage Air Compressor

Technical Data

| | SAC-30 | SAC-50 | SAC-75 | SAC-100 | SAC-150 |
|----------------------------------------|------------------|----------------------------|--------|---------|---------|
| Power (HP) | 3 | 5 | 7.5 | 10 | 15 |
| Compressor(RPM) | 975 | 710 | 975 | 710 | 943 |
| Tank Capacity(ltrs.) | 160&220 | 250 | 250 | 420 | 500 |
| Working Pressure (kg/cm ²) | 12 | 12 | 12 | 12 | 12 |
| Free Air delivery (LPM) | 263 | 390 | 536 | 781 | 1036 |
| No. of Cylinder | 2 | 2 | 2 | 3 | 3 |
| Power Supply | 220V AC, 1 Phase | 380-415V AC, 3 Phase, 50Hz | | | |

Rotary Screw Compressor Belt Driven & Direct Driven

Features :-

- Air end with high-efficiency
- Double Screw with low noise
- Elegant compact design
- 100% Continuous duty operation
- 5 micron, water-resistant air filtration material
- Super Silenced Enclosure
- Easy to use LCD control panel
- Energy efficient operation

Technical Data

| | SC-5 | SC-7 | SC-10 | SC-15 | SC-20 |
|----------------------------------------------|--------------------------|----------|---------|---------|---------|
| Free air deliver/ | 0.55/0.8 | 0.85/0.7 | 1.2/0.7 | 1.6/0.7 | 2.5/0.7 |
| Discharge pressure (m ³ /min/Mpa) | | 0.75/0.8 | 1.1/0.8 | 1.5/0.8 | 2.3/0.8 |
| | | | 0.9/1.0 | 1.3/1.0 | 2.1/1.0 |
| | | | 0.7/1.2 | 1.1/1.2 | 1.9/1.2 |
| Compression stage | Single stage | | | | |
| Ambient tem. | -5-- +45°C | | | | |
| Cooling mode | Air cooling | | | | |
| Discharge tem. | Ambient temperature+15°C | | | | |
| Lubricant (L) | 3 | 3.7 | 3.7 | 10 | 10 |
| Noise Level (Db) | 62±2 | 62±2 | 62±2 | 64±2 | 64±2 |
| Drive method | Belt driven | | | | |
| Electricity (V/ph/Hz) | 380V/3PHASE/50HZ | | | | |
| Motor power (HP) | 5.5 | 7.5 | 10 | 15 | 20 |



Nitrogen Generators

for Car/Bikes/Vans/Mini Buses and Light Trucks

One of the Tyre primary tasks to carry the weight of the vehicle, but actually the load is carried by the pressure in the tyre, hence correct tyre inflation is very important to ensure appropriate load carrying capacity & enhance tyres performance, durability which contributes to give better fuel mileage.

Nitrogen is a "slow" inactive gas labeled as inert gas due to its non-reactive nature with much material Oxygen on the other side is a "fast" active gas that reacts with many materials & the reaction is called as "Oxidation". More over N₂ is a dry gas that does not support moisture while Oxygen combined with hydrogen forms water H₂O.



Nitro Eco

Wall Mount Nitrogen Generators are specifically designed to provide on-site, high purity nitrogen for use in dry and pre-action fire sprinkler systems.

Wall Mounted

Nitro Pro



Nitro Heavy



Benefits of Nitrogen

- Reduces the tyre's running temperature.
- Improves the ride quality.
- Increases tyre life.
- Keeps tyre pressures more constant.
- Slows the rate of pressure loss.
- Doesn't react with the tyre and rim materials.

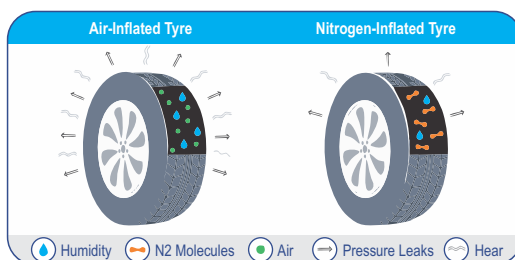

Features of Our Nitro Series

- Soft touch stainless steel switches.
- Automatic tyre detection.
- Automatic filling speed adjustment using intelligent software ensures fast inflation.
- Safe with self diagnostics and always confirms a high set point to avoid wrong set point entry.
- Auto/Manual mode selectable "PSI/BAR" unit

Technical Data

| Code | Power Supply | Power | Nitrogen Purity | Operating Temp | Compressed Air Pressure Required | Nitrogen Output | Hose | Range | Tank |
|--------------------|---------------|-------|-----------------|----------------|----------------------------------|-----------------|---------|---------|-----------------|
| Nitro Eco | 220V/50~60 Hz | 25 W | 95 – 99.5 % | -20°C - 70°C | 174 psi | 2000-4000 L/Hr. | 10 Mtr. | 150 psi | ----- |
| Nitro Pro | 220V/50~60 Hz | 25 W | 95 – 99.5 % | -20°C - 70°C | 174 psi | 2000-4000 L/Hr. | 10 Mtr. | 150 psi | 85L (Build-in) |
| Nitro Heavy | 220V/50~60 Hz | 25 W | 95 – 99.5 % | -5°C - 70°C | 174 psi | 2000-4000 L/Hr. | 20 Mtr. | 230 psi | 300L (Build-in) |

EXACT-150/230/M150

Automatic Tyre Inflator Wall Mount/with Stand

Technical Data

| | EXACT-150/230 | EXACT-M150 |
|----------------|------------------------------------|------------------------------------|
| Display Type | Back lit 1" LCD | Back Lit 1" Dual LED |
| Reader Unit | Digital Display | Digital Display |
| Hose Length | 10 mtrs | 10mtrs |
| Pressure Range | 150 PSI/230PSI | 0-150 PSI |
| Accuracy | ±0.02bar ±0.3psi ±2kpa ±0.02kgf | ±0.02bar ±0.3psi ±2kpa ±0.02kgf |
| Operation | Auto Inflation, deflate | Auto Inflation, deflate |
| Supply Voltage | AC 110-240V/50-60HZ | 220V |



Mobi Tyre Inflator/Deflator with Bluetooth Connectivity

- Design for Petrol pumps and service center.
- Soft touch membrane keypad.
- Max Pressure 10 Bar.
- Mobile application gives you the full control.



ATI WITH STAND

LIFFE-BP4T/HC4T

Two Post Lift for Cars & LCV's



| Technical Data | | |
|-------------------------|----------------------|----------------------|
| Code | LIFFE-BP4T | LIFFE-HC4T |
| Lifting capacity | 4 Ton | 4 Ton |
| Overall height | 2844 mm | 3620 mm |
| Lifting time | <45 sec | <45 sec |
| Drive through clearance | 2579 mm | 2640 mm |
| Maximum lifting height | 1800 mm | 1800 mm |
| Minimum lifting height | 110 mm | 110 mm |
| Lifting arm adjustments | Front & Rear | Front & Rear |
| Power supply | 1 Phase 3Phase, 50Hz | 1 Phase 3Phase, 50Hz |
| Power | 3.0 HP | 3.0 HP |

Features :-

- Thickened Column, stable & durable
- Dual hydraulic "Direct-Drive" cylinders.

- Drop-end arms provide a lower pad height.
- Base plate design suitable for lowering ceiling work shop.



LIFFE-FPL-4T/5T

For Post Lift for Cars & LCV's

| Technical Data | |
|------------------|-------------------|
| Code | LIFFE-FPL-4T/5T |
| Lifting capacity | 4 Ton/ 5 Ton |
| Overall height | 1700 mm |
| Secondary jack | 470 mm |
| Platform height | 175 mm |
| Platform length | 4200/4500/5000 mm |
| Lifting time | 50 sec |
| Power of motor | 220v 1ph 50/60Hz |
| Power supply | 2.2 kw |

Features :-

- Strong hydraulic cylinder
- Flat runway design
- Height limit switch

- Safety valve for anti-explosion of hydraulic system
- Manual lock release from single point, easy to operate.
- Cylinder located inside of runway, perfectly protected.

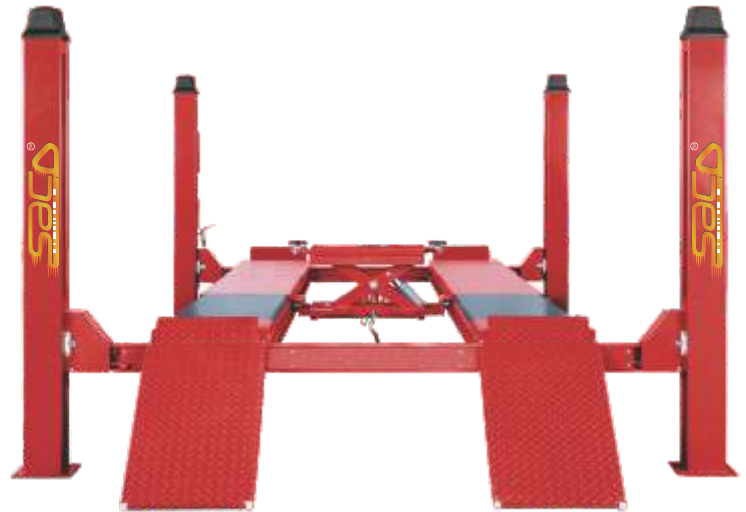

- New outstanding 4 post lift, gathering with the preferences shape the lift produced by **SKYTECH**
- It actualizes new safe lifting innovation of the world as one, included, electrical control and mechanical control.

LIFFE-WASL-4T

Wheel Alignment Scissor Lift



Features :-

- **SKYTECH** Alignment lift is the next evolution in industrial-strength lifting technology.
- 4 Ton of true vertical lifting power for a more compact footprint will better accommodate smaller service bays and work areas.

| Technical Data | |
|------------------|------------------|
| Code | LIFFE-WASL-4T |
| Lifting capacity | 4 Ton |
| Lifting height | 1800 mm |
| Secondary jack | 470 mm |
| Min height | 360 mm |
| Platform width | 600 mm |
| Platform length | 4200 / 4500 mm |
| Lifting time | 37 sec |
| Power of motor | 220v 1ph 50/60Hz |
| Power | 2.2 kw |

LIFFE-MR-3T

Mid Rise Scissor Lift

Mid-rise scissor lifts are perfect for home garages with low ceilings. They're also popular in service bays and detail shops nationwide. They offer exceptional comfort when performing wheel and brake service. They also permit more ergonomic body positioning when detailing wheel wells and hard-to-reach rocker panels.



| Technical Data | |
|------------------|---------------|
| Code | LIFFE-MR-3T |
| Lifting capacity | 3 Ton |
| Lifting height | 1000 /1200 mm |
| Lifting time | <40 sec |
| Platform width | 530 mm |
| Platform length | 1400-1740 mm |
| Power supply | 220 V / 380 V |
| Motor power | 2.2 kw |

LIFFE-LR-3T

Portable Low Rise Lift With Swivel Swing Arms (Air Operated)

Portable Vehicle Lift is ideal for many applications including body repair, vehicle inspection & estimation, tire change & rotation, detailing and brake work.

The dolly handle and attached wheels provide an easy way to move the lift anywhere in the shop.



| Technical Data | |
|------------------|---------------|
| Code | LIFFE-LR-3T |
| Lifting capacity | 3 Ton |
| Lifting height | 700 mm |
| Lowered height | 92 mm |
| Lifting time | <25 sec |
| Platform width | 965 mm |
| Platform length | 1270 mm |
| Air Input | 60-120 psi |
| Controller | Hand Operated |

LIFFE-HR-3T

High Rise Scissor Lift

Full-rise scissor lifts are popular in body shops, professional service bays and even home garages. It takes up a minimal amount of floor space, so it fits nicely into narrower bays.



| Technical Data | |
|------------------|---------------|
| Code | LIFFE-HR-3T |
| Lifting capacity | 3 Ton |
| Lifting height | 2050 mm |
| Lifting time | <45 sec |
| Platform width | 550 mm |
| Platform length | 1540-1740 mm |
| Power supply | 220 V / 380 V |
| Motor power | 2.2 kw |

LIFFE-WL-4T/4T

Hydraulic Washing Lifts

SKYTECH is one of the leaders in hydraulic washing hoist segment. Our lifts can be used for washing and lubrication of all types of passenger and commercial vehicles.

- Supports both indoor & outdoor Installation.
- High-grade steel plungers manufactured to close tolerance with hard chrome plating for high wear-resistant.
- Uniquely designed wiper rings to prevent entry of water and dirt particles into the hoist cylinder while raising, servicing and lowering.



| Technical Data | | |
|--------------------|--------------|-------------|
| Code | LIFFE-WLB-4T | LIFFE-WL-4T |
| Lifting capacity | 4 Ton | 4 Ton |
| Lifting height | 1520 mm | 1520 mm |
| Lifting time | 55 sec | 50 sec |
| Operating Pressure | 7 Kg/cm2 | 7 Kg/cm2 |

QJY-ZX

Build-up Movable Hydraulic Lift

Mobile Column Lift system comes in a set of 4. When combined, the system lifts up to 5~7 Ton. Ideal for two-axle vehicles. Sets of 2, 6 and 8 are also available.



Features

- ✓ High lifting capacity with cable synchronization control.
- ✓ 24V power control box ensure safety operation.
- ✓ Movable, can be used indoors and outdoors.
- ✓ Available in 5T/post or 7.5T/post design.
- ✓ Every column is movable, width between columns adjustable.
- ✓ Dynamic test with 125% of rated capacity and static test with 150% of rated capacity.
- ✓ CE certificated.

| Technical Data | | | | | |
|----------------|----------|----------------|-------------|--------------|--------------------------------------|
| Code | Capacity | Lifting height | Motor power | Power supply | External Dimensions of vertical post |
| QJY-ZX5 | 5000kg | 1500mm | 3kw | 380V | 1120x1100x2600mm |
| QJY-ZX7 | 7500kg | 1500mm | 4kw | 380V | 1120x1100x2600mm |

LIFEE-10T

4 Post Bus Lift

Four post design allows complete under-vehicle access for all types of repair without side obstructions like scissors and parallelogram lifts. Indoor or outdoor installation quick & easy.



| Technical Data | |
|------------------|------------------|
| Code | LIFEE-10T |
| Lifting Capacity | 10000kg |
| Lifting Height | 1500mm |
| Overall Height | 2400mm |
| Overall Width | 3972mm |
| Overall Length | 9600mm |
| Motor Voltage | 220V or 380V |
| Phase | 1ph or 3ph |

HPT-SC-15T-68S

Portable Car Lift

The Portable Car lift can be used for lifting Car, Off-road Car, SUV and MUVs. The system consists of a single column, electrical components to be connected only to the user's power outlet.



Area of Applications

- ✓ Quick Initial Inspection
- ✓ Insurance Surveys
- ✓ Suspension Repair
- ✓ Wheel Rotation
- ✓ Oil Change
- ✓ Body Shop Repair
- ✓ Wheel Servicing
- ✓ Brake Servicing
- ✓ Under Body Jobs
- ✓ Body Polishing
- ✓ Bottom neon lights fixing

Electrical Components

- ✓ A single phase motor of 1.1kW at 1440 rpm for 220V (high starting torque).
- ✓ Reversing switch of three poles with a bridge for single-phase
- ✓ installation of 12 amps with return-to-zero.
- ✓ Power feeding cable RV-K 3 x 1.5 mm
- ✓ Connection switch-motor with the cable RV-K 5 x 1 mm

LIFEE-16T

Hydraulic Washing Lift

Plunger are of high grade mild steel manufactured to close tolerance with double hard chrome plating for high wear resistance and good finish. Uniquely designed wiper rings prevent entry of water and dust into the hoist cylinder.



| Technical Data | |
|----------------------|--------------------------------|
| Code | LIFEE-16T |
| Type | Double Cylinder Hydraulic Lift |
| Material used | Mild Steel |
| Maximum Load (Tons) | 16T |
| Maximum Rise (m) | 0-1.5 |
| Number of Guide Post | 2 post |

LIFFE-SL-4T

Scissor Lift

- Hydraulic system synchronize the movement of runway.
- Integrated limit switch controls is high & low lift positions.
- Easy to use and maintain control panel feature with push button controls.



| Technical Data | |
|------------------|--------------------|
| Code | LIFFE-SL-4T |
| Lifting capacity | 4 Ton |
| Lifting height | 6 Feet |
| Size (LxWxH) | 9x3x6 Feet |
| Lower height | 4 inch |
| Safety | Manual/Air locking |
| Power supply | 220 V / 415 V |
| Motor power | 3 Hp |

LIFFE-HLF-3/5/10/20T

Hydraulic Long Floor Jack

- A wide, rugged base provides stability and strength all models critical stress points are reinforced for added durability and dependability.
- Heat treated extension screw allows low pickup height adjustment and maximum lift height.
- Serrated, heat treated saddle provides generous lifting area and secure grip.
- Carrying handles on big capacity jack for easy remove.



| Technical Data | | | | |
|----------------|--------|--------|---------|---------|
| Code | HLF-3T | HLF-5T | HLF-10T | HLF-20T |
| Capacity | 3 Ton | 5 Ton | 10 Ton | 20 Ton |
| Max. height | 1220mm | 580mm | 580mm | 580mm |
| Min height | 407mm | 200mm | 180mm | 190mm |
| Weight | 29kg | 74kg | 98kg | 200kg |
| Length | 1980mm | 1440mm | 1630mm | 1750mm |
| Breadth | 559mm | 200mm | 200mm | 230mm |

LIFFE-EC-2T/3T

Engine Crane

- Heavy gauge welded steel development.
- Uncompromising full swivel casters give simple mobility what's more, situating.
- Extending blast allows numerous length modifications.
- Wide base gives controlled bringing down.
- Produced steel grab hook
- Limit 0.5 to 2 Ton/0.5 to 3 Ton.



LIFFE-TJ-1.5T

Transmission Jack

- Tough steel haggles swivel ball bearing caster.
- Multi adjustment handles guarantee that transmission support is consistently at the privilege point to position and acknowledge any load.
- Load restraining chain is imperative for raising and lowering safety.
- Four wheel casters allow easy movement, positioning of transmission jack.



LIFFE-RE

Ride Elevator

- Revolutionary invention in lifting technology.
- No concrete foundation needed like two post lift.
- Lift can be moved any where in the workshop and a bay can be created.
- Can be lifted manually or with help of a drill machine.
- Low on budget.



LIFFE-BJ-4

Air Operating Jack

- Structured with air inlet valve, Air release safety valve, pressure gauge etc.
- Quick inflation and deflation process, which is advantageous for clients.
- The compressor air pressure must be under 8kg/cm2



LIFFE-TJ-1T

Transmission Jack

The SKYTECH heavy-duty hydraulic transmission jack is designed for lifting and lowering of transmissions and differentials from various vehicles. Strong reinforced steel construction with flanged side frames provide extra strength.

- Strong reinforced steel construction with flanged side frames provide extra strength.



| Technical Data | |
|---------------------|--------------------|
| Code | LIFFE-TJ-1T |
| Type | Automotive |
| Lifting Height Max. | 33 1/2 in |
| Lifting Height Min. | 7 7/8 in |
| Lifting Capacity | 1 Ton |
| Length | 19 1/8 in |
| Base Size | 40-3/4 x 19-1/8 in |

LIFFE-GB-1T

Gear Box Jack (Mechanical)

we produce unmatched quality Gear Box Jack designed especially for Tata & Leyland Heavy Vehicles. Being made of high quality materials, our manufactured Gear Box Jacks are durable hence last longer.



| Technical Data | |
|---------------------|-------------|
| Code | LIFFE-GB-1T |
| Type | Mechanical |
| Lifting Height Max. | 600 mm |
| Lifting Height Min. | 80 mm |
| Lifting Capacity | 1 Ton |
| Length | 1100 mm |
| Overall Width | 610 mm |

Engine Crane/Jib Crane

Engine Lifting mechanical crane with ext. boom suitable for Ashok Leyland TATA, buses & trucks and all other vehicle Capacity 1.5 Ton.

Hydraulic or Mechanical engine lifting cranes makes work easy in your workshop. As it reduces breakdown and over hauling engine time and also provides safe operation as it is designed for the same. Capacity available 1/2ton, 1 ton and 1.5 ton models. They are robust in construction and effortless in operation and low maintenance.

Features

- ✓ Comes with 4 Castor wheels with locking mechanism for hassle free parking.
- ✓ Made from High quality Heavy gauge welded steel construction for added strength & durability.
- ✓ Mechanical locking ensures safety of gear box in case of any hydraulic failure.
- ✓ 1 big towing handles on back side for easy portability.
- ✓ Chain locking system for supporting engine and gear box.
- ✓ Mechanical locking system to hold the boom in position.



| Technical Data | |
|-----------------------------------------|---------------|
| Code | LIFFE-EC-1.5T |
| Load Lifting Capacity | 1500 kgs |
| Length or Jib in fully Ext. position | 1900 +/- 50mm |
| Maximum lift of the hook from the floor | 2150 +/- 50mm |
| Overall height | 2800 +/- 50mm |
| Distance between front splayed legs | 1200 +/- 50mm |



APT-25T-550

Hand Pallet Truck

Features

- ✓ Easy 3 position control handle- Raise, Lower, Neutral.
- ✓ Ergonomic power coated handle, which is comfortable and convenient to operate.
- ✓ Fork lowering speed is controllable, operated by hand control as well as foot pedal.
- ✓ Integrated casting pump & welded pump.
- ✓ Extra reinforced on fork frame.
- ✓ Solid steel lifting rods for extra strength.



HPT-SC-15T-68S

Hand Pallet Truck - Scissor

Features

- ✓ Hand brake / drive hand pallet truck.
- ✓ Easy 3 position control handle- Raise, Lower, Neutral.
- ✓ Power coated structure after shot blasting process.
- ✓ Ergonomic powder coated handle.
- ✓ Fork speed is controllable, operated by hand control and foot pedal.
- ✓ Heavy duty ball bearings for lower maintenance.

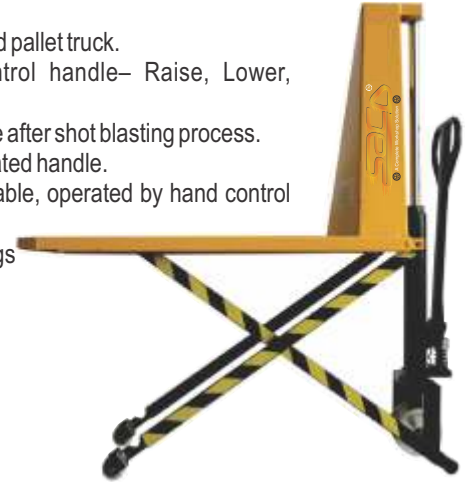

APMS-500S

Portable Scissor Table - Low Lift

Features

- ✓ Scissor table for use as a feeding table on assembly line.
- ✓ Structural heavy duty steel construction and power coated.
- ✓ Easy action foot operated hydraulic lift for raising table top to desired level.
- ✓ Its Reduce time lost to personnel injuries and help increase your facility's productivity.



HDH-350A

Hydraulic Drum Handler - V-Type

Features

- ✓ Drum size - Dia 572x900.
- ✓ Hand brake / drive hand pallet truck.
- ✓ Easy 3 position control handle- Raise, Lower, Neutral.
- ✓ Powder coated structure and Integrated welded pump.
- ✓ Its Reduce time lost to personnel injuries and help increase your facility's productivity.



| Technical Data | | | | | |
|-----------------------|--------------------|-----------------------|-------------------|--------------------|-----------------|
| Code | APT-25T-550 | HPT-SC-15T-68S | Code | APMS-500S | HDH-350A |
| Capacity | upto 2500kg | upto 1500kg | Capacity | upto 500kg | 350kg |
| Min. Fork Height | 80-90mm | 85-90mm | Min. Height | 350mm | ----- |
| Max. Fork Height | 190-200mm | 192-205mm | Max. Height | 900mm | ~115mm |
| Fork Outside Distance | 550mm | 685mm | Table Size (LxW) | 900x600mm | ----- |
| Fork Length | 1150mm | 1220mm | Scissor | Single | ----- |
| Fork Width | 150mm | 150mm | Structure | Mild Steel | Mild Steel |
| Fork Thickness | 3.2/4.2mm | 3.2mm | Material of Wheel | Nylon/Polyurethane | Nylon/Rubber |
| Material of Wheel | Nylon/Polyurethane | Nylon/Polyurethane | | | |

ET-35

Electric Trolley

Features

- ✓ These are extensively used in various industries for carrying heavy loads from one place to another.
- ✓ Offered products are highly durable in nature and have exceptional strength and durable standards.



| Technical Data | |
|------------------|---------------|
| Code | ET-35 |
| Capacity | 350kg |
| Platform Size | 900x600mm |
| Front Wheel Dia. | 250mm |
| Rear Wheel Dia. | 150mm |
| Control | Electric Type |

High Pressure Car Washer Pumps

Our most popular and versatile units. Utilized by a multitude of businesses for a wide variety of cleaning needs.



Wall Hanging High Pressure Washer



Trolley Based High Pressure Washer



Heavy Duty High Pressure

Skytech clean supplies high quality high pressure along with advanced cleaning equipment and environmental friendly chemicals.

Our piston ceramic plunger pumps for use on cleaning units & industrial system.

Italian high quality pump.



- Solid ceramic plungers.
- Heat treated crank shafts.
- Increase work efficiency and maximized the work output.
- Stainless steel check valves.
- Heavy duty forged brass main folds.
- High strength bronze or aluminum alloy connecting rods.
- Adjustable pressure regulator
- Downstream chemical injector.
- Drain cleaning kit and a hose reel to maximize your use out of your pressure washer.

Supreme Cleaning Action

Our heavy-duty pressure washer that is engineered to deliver impressive performance to let you effortlessly clean different types of surfaces. Furthermore, the ergonomic design makes it easy to use.

High-performance Pressure Washer

This is a durable, high-performance pressure washer that is ideal for professional & industrial use.

High Pressure Accessories



Lance



360° Wash Boom



Wax Bottle Holder



Lance holder



Hose Pipe



Foam Gun with Quick Connect



Accessories Tray Holder



Foam Lance

Optional Accessories



Rotating Underbody Lance



L Shape Underbody Lance



4 Nozzle Underbody

Technical Data

| Code | CWP-30 | CWP-50 | CWP-70 | CWP-100 | CWP-150 | CWP-200 |
|----------------|--------------|--------------|--------------|-----------|---------|---------|
| Motor Power | 3Hp | 5Hp | 7.5Hp | 10Hp | 15Hp | 20Hp |
| Phase | Single | Three | Three | Three | Three | Three |
| Voltage | 230V/415V | 415V | 415V | 415V | 415V | 415V |
| Output (L/min) | 12Ltr. | 12Ltr. | 15Ltr. | 15/20Ltr. | 20Ltr. | 21Ltr. |
| Pressure (bar) | 140 | 170 | 200 | 200/250 | 300 | 350 |
| RPM | 1450 | 1450 | 1450 | 1450 | 1450 | 1450 |
| Weight | 40 | 45 | 70 | 90 | 90 | 190 |
| Starter | Dual | Dual | Dual | Dual | Delta | Delta |
| Body Cover | SS/MS | SS/MS | SS/MS | SS/MS | SS/MS | SS/MS |
| Stand Type | Trolley/Wall | Trolley/Wall | Trolley/Wall | Trolley | Trolley | Trolley |

High Pressure Car Washer Pumps

Triplex Pumps-High Pressure | Single Plunger

- Used in various industrial and commercial sector, these products are easy to install and offer reliable performance.
- These machines are simple to maintain, high in performance, and ensure efficient cleaning of cars.



| Code | Technical Data (Triplex Pumps) | | | Technical Data (Single Plunger) |
|--------------------|----------------------------------|---------------------------------|---------------------------------|-------------------------------------------|
| | ATP 01/02 | ATP 03 | ATP 05 | ATW 03 |
| Type | Reciprocating | Reciprocating | Reciprocating | Reciprocating |
| No of Plunger | 3 | 3 | 3 | 1 |
| Speed (RPM) | 580 | 360 | 340 | 360 |
| Working Pressure | 18-40kg/cm ² | 45-60kg/cm ² | 80-100kg/cm ² | 25kg/cm ² |
| Crankcase oil Cap. | 750ml | 1250ml | 1250ml | 400ml |
| Hose & Gun | 1 No. each | 1 No. each | 1 Trigger gun with bypass valve | 1 Trigger gun with bypass valve |
| Motor | Single phase branded motor- 1 HP | Three phase branded motor- 3 HP | Three phase branded motor- 5 HP | Three phase 3 HP/ 4 HP branded Heavy Duty |
| Output (LPM) | 13 Ltrs | 18 Ltrs | 14 Ltrs | 12.5 Ltrs |
| Hose Length | 6m | 8m | 8m | 6m |

Fg23 Foam Gun for Car Washing

Features

- Fill the bottle with hot/warm water before adding soap
- Adjust the spray nozzle first to find the stream of water that works for you



| Technical Data | |
|----------------|--------------|
| Code | Fg23 |
| Max. pressure | 5000 psi |
| Max. flow | 5.3 (US gpm) |
| Max. temp. | 140 F |
| Air inlet | 1/4" |
| Nozzle size | 1.25 |

FT24SS S.S. Foam Tank

Features

- All stainless steel 2-wheel cart. Ready-to-use chemical from the 70L tank.
- It injects compressed air into the solution to greatly increase volume and coverage ability and projects rich, clinging foam through the discharge hose, wand and fan nozzle.



| Technical Data | |
|--------------------|---------------|
| Code | FT24SS |
| Operating Pressure | 1~2 bar |
| Capacity | 70 lit |
| Max pressure | 3 bar |
| Weight | 12kg |
| Size (LxBxH) | 45x41x80 |

VC-15/30/70/80

Vacuum Cleaners

The multi-purpose range of vacuum cleaners are ideal for interiors of the car workshop, garages and outside areas. An intelligent machine design that is energy efficient and optimized for maximum performance in all the applications.



| Technical Data | | | | |
|----------------|-----------|-----------|-----------|-----------|
| Code | VC-15 | VC-30 | VC-70 | VC-80 |
| Function | Dry & Wet | Dry & Wet | Dry & Wet | Dry & Wet |
| Capacity | 15L | 36L | 70L | 80L |
| Vacuum suction | 180m bar | 230m bar | 250m bar | 280m bar |
| Air flow rate | 42 L/s | 53 L/s | 106 L/s | 106 L/s |
| Rated voltage | 220V | 220-240V | 220-240V | 220-240V |
| Tank Dia | 345mm | 345mm | 440mm | 440mm |
| Hose Dia | 36mm | 38mm | 40mm | 40mm |

UC-27

Upholstery Cleaners

Light weight design makes it easy to clean stairs, upholstery and more.

Multi-Purpose Tool Scrub to lift and remove tough spots and unexpected spills on your carpets, stairs and upholstery.



| Technical Data | |
|-------------------------------|--------------|
| Code | UC-27 |
| No. of Motor | 1 |
| Maximum (Watt) | 1200 |
| Supply (Volt/Hz) | 220-250 |
| Suction (mm H ₂ O) | 210 |
| Air Flow (m ³ /hr) | 48 |
| Container Tank (Ltr) | 27 |
| Detergent Tank (Ltr) | 0.8 |
| Pump | 2 Bar |

RUB-200

Robotic Underbody System

The system is provided with robotic undercarriage wash with nine oscillating nozzles as a moving gantry covering corner of the undercarriage from front to back, complete system is provided with relay logic control and sensors for locating the vehicle and also selecting the vehicle length with easy operating remote panel.

Features :-

- Washing done by this machine reduces time, man power and cost.
- Manual pressure regulator gun is provided to clean the wheel arches and engine bay.
- High pressure is generated by a 7.5HP vertical multistage pump.
- Automatic car length sensing.
- Suitable for Off roaders, Cars and SUVs etc.
- Digital counter counts the number of cars being washed.

| Technical Data | |
|-------------------------------------------|--------------------------------|
| Code | RUB-200 |
| High pressure triple ceramic plunger pump | 20/42 Ltr.min |
| Nozzle Pressure | 200bar |
| Power | 7.5Hp/10Hp |
| Time Required for Underbody Wash | 1.5 min p/vehicle |
| Washing Length | 6mtr |
| Total No of Nozzles | 3/9 nozzles |
| Nozzle Types | Nozzle with oscillating system |
| Automation Type | Fully automatic panel |
| Water Proof Standard Switch | Ip65 |
| Gantry Type | Robotic |



Robotic Underbody



JCW-400

Touchless Jet Car Wash with Dryer



SKYTECH JCW-400 combines the action of three variable frequency drives to control the speed of linear motion, lateral movement and spin. All of these controls, managed by advanced software, result in a highly effective and rapid touchless wash. **SKYTECH JCW-400** combines the action of three variable frequency drives to control the speed of linear motion, lateral movement and spin. All of these controls managed by advanced software, result in a highly effective and rapid touchless wash, which also achieves significant saving when compared to other touchless systems.

JCW-500

Automatic Touchless Jet Car Wash



SKYTECH JCW-500 Jet wash uses the principle of high pressure water jets to displace dirt, grease and other foreign particles that get attached to the surface of the vehicle. Water droplets are compressed under pressure and ejected from a fine nozzle, giving it a very high kinetic energy. This kinetic energy when applied to the principle of dirt dislodges it from the surface and let it flow down with the detergent. The result is a shining vehicle within no time at all.

Features :-

- Compact design
- Long working life
- Optimum operational efficiency

Advantage :-

- Low water consumption
- Less time per vehicle
- Easy to operate and cost effective

Car Wash Works on five stage :-

- Stage 1 Robotic under body wash
- Stage 2 Pre jet wash
- Stage 3 Foam spray & wheel wash
- Stage 4 Wax Spray
- Stage 5 Final Jet wash

| Technical Data | | |
|-------------------------------------------|---------------------------------------|---------------------------------------|
| Code | JCW-400 | JCW-500 |
| High pressure triple ceramic plunger pump | 42 Ltr.min | 40 Ltr.min |
| Nozzle Pressure | 150bar | 150bar |
| Power Requirement | 15 Kw | 11-12 Kw |
| Water Consumption per vehicle | 100 - 120 Ltr | 120 - 140 Ltr |
| Washing Time | 8-9 mints | 6-8 mints |
| Wheel wash | Yes | Yes |
| Chemical wash | Automatic | Automatic |
| Automation | PLC with HMI control system | PLC with HMI control system |
| Under washing | 9 Oscillating Nozzle | 9 Oscillating Nozzle |
| Machine structure | Hot Dip Galvanized and Powder Coating | Hot Dip Galvanized and Powder Coating |
| Dimension LxWxH | 6.8x2.2x2.6 Mtr | 6.0x2.2x2.6 Mtr |

EST-100

Electric Steamer

Steam is a truly unique element that allows us to clean and sanitize every washable surface without using chemical detergents that can damage health & the environment.



- Effectively remove stubborn dirt, stains and marks.
- Light and easy to use.
- Appropriate for cleaning large areas

| Technical Data | |
|------------------|------------------------------|
| Code | EST-100 |
| Steam Tem. | 160 Deg Co |
| Water tank | 10 Ltr. |
| Steam pressure | 5-6 Bar |
| Power | 9 Kw |
| Voltage | 220/415V |
| Weight | 26kg |
| Pre heating time | 10 Mint |
| Material | Stainless Steel/Power Coated |

CSC-200

Compact Steam Cleaner

CSC-200 is equipped with the most heat efficient diesel boiler and generates powerful steam jet. It can be used for car wash, general cleaning, weed removal and more in mobile locations.



| Technical Data | |
|------------------|----------------|
| Code | CSC-200 |
| Steam Tem. | 148 Deg Co |
| Water tank | 2.2 Ltr. |
| Steam pressure | 4 Bar |
| Power | 2000 watt |
| Voltage | 230 |
| Weight | 8.4 kg |
| Pre heating time | 10 Mint |
| Material | ABS |

SCHP-50/70

Hot and Cold High Pressure Machine

This commercial high pressure hot water cleaner is ideal to use in Automobile, Hospitality, Engineering Industry etc to De-Grease only surface and stubborn scale.

Use:

The use of the hot water combined with high pressure successfully removes the most toughest of dirt and musk.

Suitable:

Extremely efficient for washing of any vehicle like Truck, Buses, Automobiles, House Vans, Motorcycles, Trains mechanical parts, oil and wine silos any industrial floor, parking areas, roofs, external walls etc.



Hot & Cold machine manufacturing & customized as per required SPECIFICATION.

Standard Accessories

- 10 Mtr. Hose
- Gun
- Insulated Gun with Lance

| Technical Data | | |
|--------------------|------------------|------------------|
| Code | SCHP-50 | SCHP-70 |
| Operating pressure | 170 bar | 200 bar |
| Flow rate | 13L/min | 15L/min |
| Inlet water Temp | 0 to 150 Celsius | 0 to 150 Celsius |
| Electric motor | 5 Hp | 7.5 Hp |
| Power | 415V | 415V |
| Weight | 110 kg | 150 kg |

SB-26/15 — Steam Booster

Car Wash using just bit of water environment friendly system, wash & wax steam booster systems produce nothing but steam meaning firstly that less water to used, the steam booster systems can clean a car using approximately 10 liters of water, whereas a conventional power washing system uses closer to 100 liters of water per vehicle. The steam booster system allows every area of the vehicle be cleaned to a biological and forensic standard without leaving behind any waste water, foam or chemical and meaning no disposal facilities or equipment are required.



Steam Booster Car Washer



SB-15



Steam Booster Car Washer

| Technical Data | | |
|----------------------|---------------------------|---------------------------|
| Code | SB-15 | SB-26 |
| Hose length | 10 Mtr. | 10 Mtr. |
| Water tank | 15 Ltr. | 26 Ltr. |
| Wax tank | 10 Ltr | 10 Ltr |
| Diesel fuel | 10 Ltr. | 10 Ltr. |
| Voltage frequency | 230v/50Hz | 230v/50Hz |
| Electric consumption | 200W | 200W |
| Steam generator | Diesel fires coil tech. | Diesel fires coil tech. |
| Operating Tem. | 100~150 C | 80~90 C |
| Preheating time | Below 1 Min. | Below 1 Min. |
| Water Consumption | 600~1200cc/min. | 600~1200cc/min. |
| Material | HDPE body | Stainless steel body |
| Automatic wax mixing | on/off function with time | on/off function with time |
| Weight | 85 kg | 120 kg |
| Dimension (LxWxH) | 85x60x85 cm | 35x25x33 cm |



Safety Features

- ✓ Service Pressure Switch
- ✓ Service Thermostat
- ✓ Safety Thermostat & Pressure Release Valve

Consumable Products



Micro Fiber Clothe



Glass Micro fiber Cloth



Wash Mitt



Car Polisher



Colored Foam



Upholstery Chemical



Jet wash Wax



Car Perfumes



Multi Purpose Polish

AC-Cyclon

AC Gas Recovery Machine

We are a reputed entity in the industry, actively engaged in offering an optimum quality range of Automatic AC Gas Recovery Machine. Powerful and heavy duty gas recovery machine with large capacity compressor and vacuum pump specially designed for Truck Bus mini Bus etc.



Heavy Duty Truck/Bus AC Gas Recovery Machine

Powerful and heavy duty gas recovery machine with large capacity compressor and vacuum pump specially designed for Truck Bus mini Bus etc. With 20 kg refrigerant capacity.

Features

- ✓ Fully automatic machine (recovery, recycling, vacuum, leak, test, recharging)
- ✓ Filter in recovery line to eliminate humidity & acidity
- ✓ Manual air purge from refrigerant tank
- ✓ Automatic high pressure protection from compressor
- ✓ Auto calibration mode
- ✓ Caution & error message / prompt
- ✓ Self diagnosis for checking the fitness of the machine
- ✓ Vehicle data base (up to 500 vehicles, in touch screen mode)
- ✓ Software update through USB interface (in touch screen mode)
- ✓ Shock proof protection for load cells
- ✓ Quick coupler provision for new oil & used oil bottle.

TF-60

AC Leak Test Detector

Features

- ✓ Flexible probe
- ✓ Super sensitive sensor
- ✓ Suitable alarm for leak detection



Technical Data

| Code | AC-Cyclon |
|-------------------------|--------------------|
| Automatic Grade | Automatic/Manual |
| Application | Ac system flushing |
| Compressor | 12 CC /200 gm/m |
| Recovery Speed | 350gm per minute |
| Type Of Refrigerant | R134a and r22 |
| Power supply | 230/110 VAC +/-5% |
| Power Consumption | 900 W |
| Capacity | 84 -100 LPM |
| Vacuum Pump | 4 CFM 1/4hp |
| Refrigerant bottle Cap. | 12 kgs |
| Weight | 70 kg |

Precise-ICT-Car

Computerized Injector Cleaning & Testing Machine

- ✓ Machine can perform cleaning & testing of top feed and side feed multipoint, mono/single point fuel injector for all type of MPFI vehicles.
- ✓ Machine can operate either 20230V AC +/- 10% or 12V DC @15AMP battery supply
- ✓ Machine will give "ALARM" at the end of each cleaning & testing.
- ✓ Any operation can be "HOLD" at any time during cleaning & testing.
- ✓ Machine will depressurize the rail after cleaning & testing by "DRAIN" key to avoid any wastage of chemical



Precise-ICTC-SA

Semi Automatic System Functionality

- ✓ Leak test
- ✓ R.P.M. test (500-9000)
- ✓ Clean
- ✓ Pluse flow test
- ✓ Drain

Fully Automatic System Functionality

- ✓ Clean
- ✓ Pluse flow test
- ✓ Drain
- ✓ Injector coil test
- ✓ Emergency panel
- ✓ Digital AC voltage display
- ✓ R.P.M. test (500-9000)
- ✓ Leak test
- ✓ Open flow test
- ✓ Hold
- ✓ Solenoid valve
- ✓ Pressure regulator



Precise-ICTC-FA

Precise-ICT-Bikes

Bikes fuel Injector Cleaner & Analyzer

- ✓ Micro controller based control system.
- ✓ Any operation time can be adjusted as per requirement.
- ✓ Can be used in automatic or manual mode selectable.
- ✓ Can clean & test petrol injectors of bike.
- ✓ Machine can be operated on 230VAC +/- 10V @50Hz supply.
- ✓ Fully enclosed PP tank for rust free operation.
- ✓ 2 Nos barosilicate glass tubes for better visibility and toughness.
- ✓ Solenoid valves gives at bottom of glass tubes for automatic draining of chemical after injector testing.
- ✓ Pressure regulator provided for fuel flow control.
- ✓ Detachable AC mains cord with inlet socket with in build AC fuses holder.

System Functionality

- ✓ Clean
- ✓ Pluse flow test
- ✓ Drain
- ✓ Leak test
- ✓ R.P.M. test (500-9000)
- ✓ Solenoid valve
- ✓ Pressure regulator
- ✓ Open Flow test



Precise-ICTB-YB
For Yamaha Bikes



Precise-ICTB-BMW
For BMW & Benelli Bikes

BrakeCheck

The BrakeCheck is our portable, DVSA-approved Brake Tester.

The Bowmonk BrakeCheck is a fully self-contained, user-friendly, portable brake tester, used by workshops, government traffic authorities and Authorised Test Facilities (ATF's) around the world to record the braking efficiency and percentage of braking imbalance of all classes of vehicle from a Motorcycle to an HGV, in a matter of minutes.

Features

- ✓ 3-Axis Accelerometer
- ✓ Audio Signal
- ✓ Measures Peak Acceleration Left/Right
- ✓ Calculates Stopping Distance
- ✓ Measures Peak Deceleration
- ✓ Measures Average Deceleration
- ✓ Vehicle pulls Left/Right indication and value
- ✓ Measures Ambient Temperature in °C and °F

- ✓ Portable
- ✓ DVSA-approved
- ✓ Easy to Use
- ✓ For all Vehicle Classes
- ✓ Tests Service and Hand Brake
- ✓ Suitable for ABS-equipped Vehicles
- ✓ Portable Printer Available
- ✓ Download Data to PC
- ✓ Printer, Carry Case and Software Available
- ✓ Motorcycle Mounting Bracket Available
- ✓ Multiple Variants for Different Vehicle Types
- ✓ Optional built-in GPS receiver



Ammo-Pro

Quick Battery Charger and booster for Car

Features

- ✓ Can be used as fast battery charger or booster.
- ✓ Heavy duty caster wheel.
- ✓ Heavy duty battery terminal for 12V & 24V
- ✓ Digital voltmeter for battery Voltage testing.
- ✓ Digital preset timer provided for selecting battery boosting time.
- ✓ Digital ammeter with selectors witch for setting charging & boosting current.
- ✓ Heavy duty toggle switches.
- ✓ Can charge upto 200AH battery.
- ✓ On-line charging, no need to pull battery from vehicle.
- ✓ Fully powder coated body.
- ✓ Long handle with fine plating.



Ammo-Heavy-48/72/96/144V

Digital Car/Truck Battery Charger

Features

- ✓ Can Charge multiple batteries (selectable) at a time.
- ✓ Heavy duty selector switches for current and voltage selection.
- ✓ Selectable voltage and current range.
- ✓ Accurate digital DC ammeter.
- ✓ Heavy duty ON/OFF switch with indicator.
- ✓ Portable type table top model



Safety Features

- ✓ Reverse polarity protection
- ✓ Over Current protection
- ✓ Electronic fuse (Resettable)

Ammo-700PH

Battery Tester for Motorcycles, Cars & LCV's

Features

- ✓ Integrated thermal printer battery tester. Designed for testing all types of 6V and
- ✓ 12V starting batteries, including lead-acid, GEL and AGM, bad cell detection and capability.
- ✓ Voltmeter mode for testing both the starter and the charging system, anti-sparking Clamps for safe operation.
- ✓ Back-lit display, 4 lines 16 characters LCD for easy viewing.



| Technical Data | |
|----------------------|------------------------------|
| Code | Ammo-700PH |
| Detachable Test Lead | 50cm/2" |
| Screen Size | 76mm x 39mm |
| Voltmeter | 7.6V ~ 17V via Battery Clamp |
| Weight | 0.52kg |
| Clamp Size | 90mm |
| Test Range | 100-1400 CCA |
| Voltage | 12V |

Launch-X431Pro

Engine Scanner

This is a new type of auto diagnostic device, completely based on Android system. covers all the essential features needed in a day to day garage work which include vast coverage of car modules, precise test data, strong diagnostic functions and many other special functions. Through its Bluetooth connectivity, communication between diagnostic connector and main device becomes easy.

Software

- ✓ Full vehicle system coverage of over 110 brands.
- ✓ Compatible with immobilize and WIFI printer.
- ✓ Integrated lookup table of vehicle coverage.
- ✓ One-click upgrade and silent install of software.
- ✓ Auto ID VINs in seconds.
- ✓ 11 special functions.
- ✓ Remote diagnosis.
- ✓ Integrated database with comprehensive vehicle service and repair information.
- ✓ Diagnostic records and reports to be stored in the cloud.

Hardware

- ✓ Android 7.0 operating system with four-core processor for fast and reliable operation.
- ✓ 8-inch touch screen display with high resolution.
- ✓ Type C interface.
- ✓ DBS Car IV VCI with stable Bluetooth connectivity.
- ✓ Push-Push connector.

Reset

Break reset, Oil reset, SAS reset, Bat. rest, Bleeding, Elec, Throttle learn, DPF reg. Gear learn, IMMO., Injector, TPMS reset and more.



Vehicle Coverage (LCV)

- ✓ Ashok Leyland,
- ✓ Tata Motors,
- ✓ SML Isuzu,
- ✓ Force Motor,
- ✓ Mahindra

Passenger Vehicle

- ✓ Asia - Mahindra (India), Tata (India), Maruti (India), Honda, Hyundai, Toyota,
- ✓ Nissan, KIA, Mitisubishi and many more.
- ✓ Europe - Audi, BMW, Fiat, Bentley, Seat, Skoda, Volvo, VW, Euroford,
- ✓ Jaguar, Maserati, Lamborghini, Ferrari, Benz, Porsche, and Many more
- ✓ American - Fiat, GM, Jeep, Ford, Chevrolet, Holden, Buick, Lincoln and more.



| Technical Data | | |
|----------------|-------------------|--------------------|
| Code | X431 Pro | X431 Pro GT |
| OS | Android 7.0 | Android 7.0 |
| CPU | 1.3Ghz 4-core | 1.5Ghz Quad-core |
| Memory | 2GB | 2GB |
| Display | 8-inch screen | 1280x800 IPS Tech. |
| Storage | 32 GB | 32 GB |
| Camera | rear 5mega pixels | --- |
| Dimension | 226x203x43.6(cm) | 300x170x42(mm) |
| Work Tem. | 0°C - 50°C | 0°C - 50°C |

Note : BS6 and urea test (DPF Reg.) Available in this software.



Supreme-EDM

Engine Decarbonizing Machine (Petrol/Diesel)



Benefit of Decarbonising

- ✓ Fuel saving up-to 15%
- ✓ Restore power by 40%
- ✓ Enhanced engine life
- ✓ Pollution control up-to 50%
- ✓ Smoother vibration free ride

- ✓ This is Micro controller based fully automatic machine.
- ✓ Machine can Decarbonize any Petrol/Diesel Engine of all type of automatic vehicle.
- ✓ Different detachable adapters for connecting machine with vehicle make it much easier for operation.
- ✓ Digital Timer is provided for easy operation / controls of machine.
- ✓ Machine can be operated either on 230V AC +/-10% or 12V DC @ 10 AMP. battery supply.
- ✓ Heavy duty operating switches gives for maintenance free operation.
- ✓ Quick release couplers are provided at the end of connecting pipes to avoid chemical spillage.
- ✓ Machine will sounds up Buzzer at the end of Decarbonizing process.
- ✓ Transparent oil level indicators available on each tank.



KPL-4L

KPL/Mileage Tester



- 4 Lts. fuel capacity
- Built in pump & accurately graduated for measuring fuel consumption of MPFI cars.
- Compatible with petrol/diesel engines.
- Weight: 4.5kg approx

KPL Advantages

The Mileage of all type of vehicles can be tested and analyze for root cause.

Supreme-Hydro

Hydrogen Engine Decarbonizing Machine

Features

- ✓ Increase Mileage upto 5km
- ✓ Increase Engine life span
- ✓ Increase vehicle pickup & performance
- ✓ Smoother driving experience
- ✓ Decrease engine noise & vibrations
- ✓ Reduce black smoke
- ✓ Get serviced & feel like new one

| Technical Data | |
|-------------------|---------------|
| Code | Supreme-Hydro |
| Automation Grade | Automatic |
| Power Source | 220v |
| Water Consumption | 5 ltr |
| Cooling Mode | air colled |
| Working Method | water based |



Opacio 100

Diesel Smoke Meter

Features

- ✓ It saves cost of computer.
- ✓ Most then 1 Lac test reports storing capacity.
- ✓ Monthly PUC testing repots generating facility.
- ✓ Heating time is less than 10 minutes.
- ✓ It can send data directly to server or E-mail.
- ✓ Big LED monitor to show all the parameters.



Machine to measure to measure opacity of diesel engine's exhaust smoke. The model is equipped with gas temperature pressure valve and distribution control cell to ensure accurate measurements each time.

| Technical Data | |
|-----------------------|-------------------------|
| Code | Opacio-100 |
| Display | LED Monitor |
| Oil Temperature | 20° C To 150° C Res. 1 |
| Opacity | 0 to 99.9% Res. 0.01 |
| RPM Counter | 300 To 9990 RPM Res. 10 |
| Smoke Temperature | 20 C to 400 C Res. 1 |
| Power Consumption | Less Than 100 Watts |
| Operating Temperature | 5 C- 50 C |
| Power Supply | 220 VAC 50 Hz. -10%+15% |

BM7777

Exhaust Gas Analyzer

Features

- ✓ Exhaust gas analyzer is an analyzer for control of exhaust gases from petrol/CNG/LP engines.
- ✓ High quality microprocessor based instrument with combines optical precision.
- ✓ Option of adding non thermal paper printer for printing a record of the test results.
- ✓ Ability to operate on 220V AC or a 12DC vehicle battery.



This machine is installed at Automotive outlets, pollution check outlets and petrol / CNG / LPG stations. It measures the amount of pollution emitted by petrol vehicles.

| Technical Data | |
|-----------------------|-------------------------------|
| Code | BM 7777 |
| Operating Temperature | 5 Degree C - 45 Degree C |
| Lambda | 0 to 9.999 |
| Speed | 200 to 9999 RPM |
| C0 | 0 Vol to 10.50% Vol. |
| C02 | 0 Vol to 21.0% Vol. |
| O2 | 0 Vol to 23% Vol. |
| HC | 0 PPM to 20000 PPM as Propane |
| Power Consumption | Less Than 100 Watts |
| Power Supply | 220 VAC 50 Hz. (-10 % +15%) |
| Display | LED Monitor |
| Oil Temperature | 30 Degree C to 150 Degree C |

GLD-01

Gas Leak Detector

The Combustible Gas Leak Detector has a long, slim gooseneck probe to find leaks in tight areas. It's adjustable alarm, easy one-hand operation.

Features

- ✓ Higher Sensitivity.
- ✓ Adjustable tick rate to locate leaks quickly and easy.
- ✓ Visual leak detection by LED indicators.
- ✓ Precision sensor detects even the smallest leak.
- ✓ Fast response of less than two seconds to 40% LEL
- ✓ Includes earphone jack.
- ✓ 16" gooseneck.

| Technical Data | |
|----------------|---------------------------------------------------------------------------|
| Code | GLD-01 |
| Sensitivity | 50 ppm methane |
| Sensor Type | Low power semiconductor |
| Warm up time | Approx 60 sec |
| Response time | Less than 2 sec |
| Duty cycle | Continuous |
| Probe length | 16" |
| Power supply | Cell battery |
| Alarm | Visible & Audible at 10% LEL for methane. Can be concentrations or gases. |



PRK-10

Plastic Repair Kit

Features

- ✓ Portable machine
- ✓ Automatic shutup on reaching preprogrammed temperature.
- ✓ Temperature set facility for different types of plastic body.



Technical Data

| Code | PRK-10 |
|----------------|-------------------|
| Input Voltage | AC 220V 50/60 Hz. |
| Input Current | 1.5A |
| Output Voltage | 2.6V |
| Output Current | 5.30A |
| Weight | 4.8 Kg |

AC-50C

Air Compressor

Features

- It's perfect for powering air brushes, air/ brad nailers, upholstery projects and more.
- Conveniently placed gauges are easy to read & this compressor's compact design makes it easily portable Ideal for tire and ball inflation.
- Operates on 220 volt (Single Phase) house outlet Oiled pump for maintenance-free ownership and strong, reliable motor output.
- 50 liter horizontal tank and 200 L/min. @ 90 PSI. 110 Max PSI provides plenty of power to tackle DIY projects.

Max pressure

8 Bar

Outlet

2x1/4"ball valve

Noise

92 dB

Net Weight

30 kg



Technical Data

| Code | Voltage | Input power | Speed | Tank | Air flow |
|-------|-----------|-------------|----------|--------|----------|
| AC50C | 220V/50HZ | 2.0 HP | 2850 rpm | 50 ltr | 200L/Min |

HBA-160

Head Beam Aligner

Features

- ✓ Power supply not required for Head Beam Alignment. Battery required only for use of Lux Meter.
- ✓ Supplied with extra long Rails allowing unit to be wheeled away in drive. through application.
- ✓ It takes very little space- Requires only 500mm between vehicle Head Lamp & Lens.
- ✓ It is suitable for all types of Automobiles vehicles including Passenger Cars, SUV's, LCV's and Heavy Commercial Vehicles.



Measuring Range

Max height (from G round Level) : 1500mm
Min height (from Ground Level) : 240mm

Technical Data

| Code | HBA-160 |
|----------------------|--------------------------------|
| Lux Meter | Digital |
| Indication Available | Lux Values |
| Lux Meter Range | 1 Lux to 50,000 Lux |
| Lux Digital Meter | 3 ½ Digits |
| Power Supply | 9V (6F22) Battery Digital Type |
| Accuracy | + 10 Lux |
| Column Height (Boom) | 1665 mm (from T•Base) |
| Lens Diameter | 160 mm |

AE-TB80

AE Test Bench

The test bench is compact and enables easy, fast and accurate testing of a wide range of alternator and starter motors.

Features

- Table top model.
- Build-in power source (no need of external battery).
- Capable of testing 12V/ 24V systems.
- With digital ammeter / voltmeter for easy reading.
- Proving with vacuum testing arrangement.
- Provided with 6V DC for testing excitation winding and 40/ 80V AC for testing shorting of armature / starter / motor.
- 12 / 24V starter motors up to 150A free running can be tested.



CTG-01

Coating Thickness Meter

coating thickness gauges work either on the magnetic induction principle or on the eddy current principle, depending on the type of probe used. You can select the type of probe via MENU system, or it will work automatically

Features

- ✓ Measured coating : Non-magnetic coating (e.g. paint, zinc) on steel; Insulating coating (e.eg paint, anodizing coating) on non-ferrous metals.
- ✓ Operating with MENU easily.
- ✓ Two measuring mode: CONTINUE and SINGLE mode.
- ✓ Two working mode: DIRECT and GROUP mode (4 groups).
- ✓ Statistic display: AVG, MAX, MIN, NO., S.DEV.
- ✓ Zero calibrating easily.
- ✓ Memory for 320 readings (80 for each group).
- ✓ Delete single readings and all group readings easily.
- ✓ High alarm and low alarm for all working mode.
- ✓ Low battery, error indication.
- ✓ USB interface for PC analysis software.

Precision

- 0~50um (0.1um)
- 50um~850um (1um)
- 850um~1250um(0.01mm)
- 0~1.968mils (0.001mils)
- 1.968mils~33.46mils(0.01mils)
- 33.46mils~49.21mils(0.1mils)

Guaranteed tolerance (of reading)

- 0~850 um (+/-3%+1um)
- 850um~1250 um (+/-5%)
- 0~33.46 mils (+/-3%+0.039mils)
- 33.46um~49.21mils(+/-5%)

Working relative humidity

20%~90%

Weight

100g



Technical Data

| Sensor probe | Working principle | Measuring range | Minimum curvature radius | Diameter of minimum area | Basic critical thickness | Working temperature | Size (HxDxW) |
|--------------------|------------------------|------------------------|--------------------------|--------------------------|--------------------------|---------------------|--------------|
| Ferrous | Magnetic induction | 0~1250um 0~49.21mils | 1.5mm | 7mm | 0.5mm | 0°C~40°C | 110x50x23 |
| Non-Ferrous | Eddy current principle | 0~1250um 0~49.21mils | 3mm | 5mm | 0.3mm | | |

TM-6002

Battery Impedance Tester

The Battery Tester is designed for measuring the internal impedance and open circuit voltage of the secondary battery including Nickel-metal hydride battery (NiMH), Nickel-cadmiumbattery (NiCd), Lithium-ion battery (Li-ion), Alkaline battery andlead-Acid battery.

AC four-terminal method to measure the internal impedance by eliminating lead impedance and contact impedance to get the accurate result.

Multi-display to show the internal impedance, voltage and clock of the battery simultaneously.

Pin type leads, which can easily contact the battery electrodes supplied as standard to get more accurate 4-terminalmeasurement.

ELECTRICAL SPECIFICATIONS

To ensure accuracy the ambient temperature should be 23°C ± 5°C with a humidity of 80% RH (maximum) non-condensing. In addition, perform a Zero adjustment after each range change.

Resistance Measurements

- Temperature coefficient : (±0.1%rdg ±0.5digits)°C
- Measurement current frequency : 1KHZ ±30HZ.
- Measurement open-circuit terminal voltage : 7Vp-p



Technical Data

| Measuring method | A/D conversion | Display | Input over range | No. of comparator settings | Operation temperature | Operating ambience | Operating attitude | Fuse specification |
|---------------------------------------|--------------------|-------------------------------------------|---------------------------|----------------------------|-----------------------|--------------------|------------------------|-------------------------|
| Impedance (AC four-termuna l method). | Dual slope method. | LCD display and LEDs (comparator output). | The screen displays "OL". | 99 sets. | 5°C to 40°C, | In-door use, | Max 2000m above level. | 0.5A/250V, 3.6ø x 10mm. |

MT-2

Digital Industrial Pyrometer

This is capable of non-contact temperature measurements at the touch of a button. The built-in laser pointer increases target accuracy while handy push buttons combine for convenient, ergonomic operation.

The Industrial pyrometers can be used to measure the temperature of objects' surface that is difficult to be measured by traditional (contact) thermometer (such as moving object, the surface with electric current or the objects which are hard to be touched.)

Features

- ✓ Rapid detection function
- ✓ Precise non-contact measurements
- ✓ Single laser sighting
- ✓ Unique flat surface, modern housing design
- ✓ Automatic Data Hold
- ✓ Backlit LCD Display to access Dark Areas

Wide Range Application

Food preparation, Safety and Fire inspectors, Plastic molding, Asphalt, Marine and Screen printing, measure ink and Dryer temperature, HVAC/R, Diesel and Fleet maintenance.



Technical Data

| Temperature range | Display resolution | Emissivity | Accuracy for Targets | Repeatability | Response time | Spectral response | Operating temp | Storage temp. | Power supply |
|-------------------|--------------------|---------------|----------------------------------------|---------------|---------------|-------------------|----------------|---------------|------------------------|
| -50°C to 550°C | 0.1°C | Fixed at 0.95 | -50°C ~ 20°C ±3°C 20°C ~ 550°C ±2°C | ±1°C(1.8°F) | 500ms | 8~14um | 0 to 50°C | -10 to 60°C | 9V battery, NEDA 1604A |

LM-1332

Digital LUX Meter

Features

- ✓ Low cost highest precision
- ✓ Overload indication
- ✓ Low battery indication.
- ✓ Data hold
- ✓ Zero adjustment
- ✓ Large integrated circuit design
- ✓ Sampling rate: 2.5 times/sec
- ✓ Auto Range
- ✓ Cosine Angular corrected

Technical Data

| Sensor | Battery life | Power supply | Weight | Accessories | Measuring range |
|-------------------------------|--------------|--------------|--------|----------------------------------------------|----------------------------------------------|
| Silicon photodiode and filter | About 200h | 9V NEDA 1604 | 250g | User's manual carrying case 9V battery | 20(1332A), 200, 2000, 20000, 200000Lux |



CFL-01

Digital Cable & Fault Locator

Digital Cable & Fault Locator consists of a transmitter and a receiver, which is a portable measurement instrument and can be used to detect or trace conductors and find short faults in them.

The electro-magnetic field induces a voltage within the receiving coil. The induced voltage is amplified, decoded, and converted to the original signal by the receiver and finally displayed on the screen.

Features

- ✓ Finding conductors in walls, conductor interruptions, short circuit in conductors.
- ✓ Conductor tracing in soil.
- ✓ Detecting fuses assigning current circuits.
- ✓ Tracing metallic water and heating piping
- ✓ Auto Power Off
- ✓ Backlit display

Technical Data

| Output single | External voltage detection range | Frequency range | Power supply | Voltage detection | Temperature range |
|---------------|----------------------------------|-----------------|--------------|-------------------|-------------------|
| 125khz | 12 to 400V | 0 to 60 Hz | 9V battery | approx. 0~0.4m | 0 to 40°C |



Tube Vulcanizer



JM-40



JM-90

Can repair the inner Tubes of various vehicles. The electric heating plate cast in aluminum with inbuilt Thermostat. Fast heating.40% energy saving long service life. The Main Frame is made by MS Hallow Section. Good toughness, strong and durable.

JM-90 - Operating pneumatic cylinder press with hand control valve. Can repair the inner tubes of various vehicles.

| Technical Data | |
|----------------|-----------------|
| Code | Tube Vulcanizer |
| Voltage | 220V |
| Power | 500W |
| Time Scope | 0-120 Min |
| Air Pressure | 4 kg (JM80/90) |

Tyre Spotter

Used for passenger car 145-275. Inbuilt thermostatically controlled heat plates with select timer heating, reaches operating temperature quickly for fast cure rates including tread, shoulder and sidewall.



JM-120



JM-120 H



JM-120 C

Suit of variety of models of tyres to be completed single-sided or double-sided parts of the vulcanizing operation inbuilt thermostat-controlled, ensure that the tyre vulcanizing temperature required, With Six different angles module and a special thermal silicon bags to make sure the tyre recover as the original shape after repair.

| Technical Data | |
|----------------|---------------|
| Code | Tyre Spotter |
| Voltage | 220V |
| Power | 1000W (500x2) |
| Time Scope | 0-120 Min |
| Temperature | 140-150°C |

Tyre Spotter

JM-440 : Our machine is used for Truck Tyres 8.25 – 20 thru 12.00 – 20, 9R – 12R tyres were wound repair, Inbuilt Thermostat control, with select timer heating, circuit protection, up and down heating by separate switch control. And is equipped with 7 sets of mold, can fully meet the needs of any part of the tire repair.

Ultra Manual : This Machine is used to repair Tyres in Tread area, Shoulder and bead areas for car, van & truck tyres. This Machine has Temperature Controller which is using for select temperature according to your requirements and up & down heating by separate switch control, can fully meet the needs of any part of he tyre repair. At the time of curing, tighten the heaters to a depth of 2-3mm at equal intervals of 5 minutes each.

Optional Car Plates.



JM-440



Ultra Manual



SHOULDER PLATE - TOP



SHOULDER\ SIDE WALL PLATE - BOTTOM



SIDE WALL PLATE - TOP



BEED PLATE - TOP



CROWN PLATE - TOP



CROWN PLATE - BOTTOM



SHOULDER PLATE – TOP 120mm



SHOULDER PLATE – TOP 100mm



CROWN\ SIDE PLATE – TOP 120mm



CROWN\ SIDE PLATE – TOP 100mm



CROWN \SHOULDER \ SIDE WALL PLATE – BOTTOM 120mm



CROWN \SHOULDER \ SIDE WALL PLATE – BOTTOM 100mm

| Technical Data | | | | |
|----------------|---------|---------------|------------|-------------|
| Code | Voltage | Power | Time Scope | Temperature |
| Tyre Spotter | 220V | 1000W (500x2) | 0-120 Min | 140-150°C |

Rim Straightener

7 Die/14 Die/20 Die for Steel Rims and Alloy Rims

DRS-07

7 Die Rim Straightener for Steel Rims



DRS-14

7 Die Rim Straightener for Steel Rims



DRS-20

7 Die Rim Straightener for Steel Rims



Our Rim Straightener is designed for normal & heavy load tyre shops.



All three model suitable for Indian and Imported steel rims.



It can quickly repair the bent edges and wobbling of MS Rims with lathe / hydraulic action.



Case hardened die for longer life.



Portable design, Heavy duty castors and More than 1000 installations.



Heavy duty reduction gear box with thrust bearings to take heavy starting force and eliminate the vibrations.

Technical Data

| Code | Electrical Motor | Rim Sizes | Vehicles | Dimension | Weight |
|--------|-----------------------------------|------------|--------------------------------------------|------------------|---------|
| DRS-07 | 2 HP 1440 RPM Single Phase | 12" to 16" | Maruti 800, Van, Zen, Wagon-R, | 700Wx480Dx1250H | 400 Kg. |
| DRS-14 | 2 HP 1440 RPM Single Phase | 12" to 16" | Esteem, Ambassador, Indica, Indigo, | 762Wx508Dx1250H | 470 Kg. |
| DRS-20 | 2 HP 1440 RPM Single /Three Phase | 12" to 16" | Uno, Matiz, Qualis, Tata Sumo, Safari, etc | 1300Wx600Dx1250H | 690 Kg. |

DRS-Alloy

Rim Straightener for Alloy Rims



High Technology machine.



Made in Europe with CE Approval.



Very High Quality steel used.



5 Ton Hydraulic pressure generated by high quality pump.



Zero vibration rotating shaft.



Dual operation, Dual function machine with Hydraulic and Lathe function



Marking pin used to check the mobility in the Rim.



Multiple attachments and multiple adaptors for any type of damage rim.



180 Degree rotating Lathe Bed.



Professional training by SKYTECH Team.



TSW-418P

1/2" Drive SQ. Impact Wrench



TSW-840SL

1" Drive SQ. Impact Wrench



TSW-842P

1" Drive SQ. Impact Wrench



| Technical Data | | | |
|----------------------|---------------------|-------------|--------------|
| Code | TSW-418P | TSW-840SL | TSW-842P |
| Max torque | 850Nm | 2300Nm | 2500Nm |
| Working torque | 0-620Nm | 830-2000Nm | 1000-22000Nm |
| Capacity (bolt size) | M20 | M40 | M41 |
| Free speed | (F)8000, (R)8500rpm | 4400rpm | 4700rpm |
| Weight | 1.8kg | 12.1kg | 10.9kg |
| Hammer mechanism | Twin hammer | Pin hammer | Pin hammer |
| Air consumption | 0.15 M3/Min | 0.75 M3/Min | 0.75 M3/Min |
| Air consumption | 5.3 c.f.m | 26.5 c.f.m | 26.5 c.f.m |

- ✓ Designed to easy Open and tighten the Trucks & Bus Wheel Nuts
- ✓ Pneumatic Wrenches significantly reduce the manual labor and saves nut tightening / opening time.
- ✓ High Quality Sturdy Pneumatic Impact Wrench from Shirota-Japan.
- ✓ Can easily unbolt even the toughest and rusted wheel nuts.
- ✓ Control Knobs prevents over and under torquing.

CP-871

High Speed Tire Buffer



Ideal for patchwork, roughing areas for recapping and cleaning tire moldings

Features

- ✓ High speed tire buffer
- ✓ Adjustable speed control
- ✓ Jacobs quality 3/8" (10 mm) chuck for holding buffing accessories
- ✓ Lock-offlever to prevent accidental start-up
- ✓ Rear exhaust
- ✓ Inline air-powered drills align the bit-holding chuck
- ✓ High performance Jacob's chuck
- ✓ Built in regulator for efficient control
- ✓ Perfect tool for vertical drilling

CP-887

Low Speed Tire Buffer



Power and speed for general maintenance
Good for vertical drilling and to reach confined areas

| Technical Data | | | | | | | | | |
|----------------|------------------------|-----------------------|-------------------------|------------|--------|----------------|------------|-------------|----------------|
| Code | Actual air consumption | Air inlet thread size | Average air consumption | Free speed | Length | Min. hose size | Net weight | Sound Power | Sound pressure |
| CP-871 | 368 l/mn | 1/4 " | 1 1/2 l/s | 22000 rpm | 203 mm | 10 mm | 0.79 kg | 100 db(A) | 89 db(A) |
| CP-887 | 765 l/mn | 1/4 " | 3.2 l/s | 2800 rpm | 203 mm | 10 mm | 1 kg | 100 db(A) | 99 db(A) |

IW0-4T

1" Impact Wrench IRM

Features

- ✓ Can easily unbolt even the toughest and rusted wheel nuts.
- ✓ Control Knobs prevents over and under torquing.
- ✓ Designed to easy Open and tighten the Trucks & Bus Wheel Nuts
- ✓ Pneumatic Wrenches significantly reduce the manual labor and saves nut tightening / opening time.



| Technical Data | | | | | | | | | |
|----------------|------------|---------------|-------------|-----------------|-----------|--------------|--------------|----------------|-------------|
| Code | Free Speed | Bolt Capacity | Max. Torque | Mechanism | Air Inlet | Air Pressure | Anvil Length | Moment Bound | Net. Weight |
| IW0-4T | 3200 rpm | 42 mm | 3200 N.m. | Pin less hammer | 1/2" | 8-10 kg | 9" | 1500-3000 N.m. | 16.1 kg |

IW01 ——— 3/8" Impact Wrench



(With 8 Socket Set)
8,9,13,15,17,19,3/8,5/16 mm

IW02 ——— 1/2" Impact Wrench



(With 8 Socket Set)
12, 13, 14, 15,17,19,22,24 mm

IW02C ——— 1/2" Impact Wrench



(With 8 Socket Set)
8,9,13,15,17,19,3/8,5/16 mm

IW03 ——— 3/4" Impact Wrench



(With 2 Socket Set)

IW02 ——— 1" Impact Wrench Piston Type



(With 2 Socket Set)

IW04L ——— 1" Impact Wrench Light



(With 2 Socket Set)

Technical Data

| Code | Free Speed | Bolt Capacity | Max. Torque | Mechanism | Air Inlet | Air Pressure | Anvil Length | Moment Bound | Net. Weight |
|-------|------------|---------------|-------------|-----------------|-----------|--------------|--------------|---------------|-------------|
| IW01 | 9000 rpm | 13 mm | 520 N.m. | Twin hammer | 1/4" | 6-8 kg | 3/4" | 200-400 N.m. | 1.6 kgs |
| IW02 | 7500 rpm | 18 mm | 850 N.m. | Twin hammer | 1/4" | 6-8 kg | 1" | 200-700 N.m. | 3.0 kgs |
| IW02C | 9000 rpm | 13 mm | 520 N.m. | Twin hammer | 1/4" | 6-8 kg | 1" | 200-700 N.m. | 1.6 kgs |
| IW03 | 6500 rpm | 18 mm | 1350 N.m. | Twin hammer | 1/4" | 6-8 kg | 1" | 200-800 N.m. | 2.9 kgs |
| IW04P | 4600 rpm | 31 mm | 1700 N.m. | Twin hammer | 3/8" | 6-10 kg | 1.5" | 500-1400 N.m. | 7.0 kgs |
| IW04L | 4200 rpm | 41 mm | 2180 N.m. | Pin less hammer | 1/2" | 8-12 kg | 8" | 900-1850 N.m. | 14 kgs |

ABG-06 ——— Air Blow Gun

Features

- Just connect with an air compressor, adapt to air compressor accessories tool. To blow dust, water powerfully.
- Stronger construction for high volume powerful blow off.

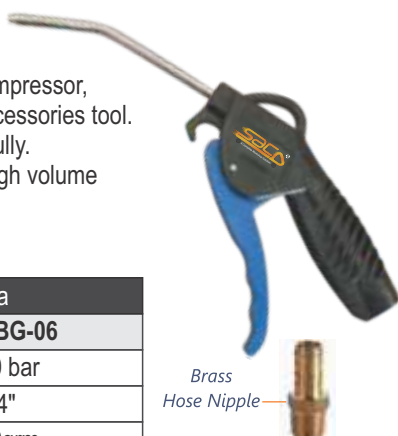

| Technical Data | |
|----------------|---------------|
| Code | ABG-06 |
| Max. pressure | 10 bar |
| Air inlet | 1/4" |
| Weight | 90gm |

H827 ——— High Volume Low Pressure

Features

- Adjustable fan pattern and fluid control for a superior finish.
- Sprays enamels, lacquers, metallic & urethane.
- High versatility for automotive and hobby projects.



| Technical Data | |
|--------------------|-------------|
| Code | H827 |
| Operating Pressure | 50 psi |
| Air Inlet | 1/4" |
| Nozzle Size | 1.4 mm |

OS512

Portable Oiling System

Ideal choice for workplace requiring movable oil dispensing systems

Recommended Use

Suitable for dispensing oils upto SAE 140 i.e Engine Oil Hydraulic Oil etc.

Includes

- Oil Master Air Operated 5:1 Pump, T512-G
- Retractable Oil Hose Reel (OMP2101)
- Oil Control Gun with Mechanical Meter (HG40)
- 210 Litre Drum Trolley & Hydraulic Hose to connect pump outlet to hose reel inlet



WOD68

Waste Oil Drain Pressurized

Oil Drain with wheel mounted tank for gravity draining of motor, engine, gearbox & differential oils, transmission & power steering fluids etc.

Features

- 10 Litres capacity bowl is height adjustable.
- Durable all-steel design & reinforced castors.
- Comes complete with a 14" telescopic bowl that can be adjusted from 45" to 72".

| Technical Data | |
|----------------------|------------------|
| Code | SKY-WOD68 |
| Tank Capacity | 68 Liters |
| Max. Collection Cap. | 55 Liters |
| Length of Hose | 2 Mtr |
| Height (Min-Max) | 45-72 inch |
| Drain pressure | 8 PSI |



GPH

Grease Pump & Oil Pump - Hand Operated

Features

- Easy to operate
- Less maintenance
- Reliable

We use advanced technologies and machineries for the process of manufacturing. These products are reckoned amongst the clients for rendering smooth performance.



GPH



OPH

| Technical Data | | | | |
|----------------|-----------|----------------------|-------------|-------|
| Code | Capacity | Pressure | Output | Hose |
| GPH | 5,10,20kg | 20kg cm ² | 4gms | 2mtr. |
| OPH | 20Ltr. | 35kg cm ² | 60ml/stroke | 3mtr. |

GPA

Grease Pump & Oil Pump - Air Operated

We offer Air Operated Oil & Grease Pumps of fine quality. They are pressurized and are used in various industries for specific operation.

These pumps are manufactured using best quality raw material by the manufacturers and are greatly appreciated for its un-interrupted performance, abrasion resistance, corrosion resistance, high efficiency and long functioning life.



GPA



OPA

| Technical Data | | | | | | | | | | |
|----------------|----------------|--------------------------------------------|------------------------|---------------------|---------------|--------------|-------------|------------|---------------|--------------|
| Code | Pressure ratio | Output at 8kg/cm ² Air pressure | Pressure range | Working pressure | Air equipment | Type of hose | Hose Length | ID of Hose | Drum Capacity | Gun |
| GPA | 50 : 1 | 320-390gms | 4-10kg/cm ² | 8kg/cm ² | 310LPH | Wire braided | 2.2Mtr | 6mm | 10/25/50kg | Trigger type |
| OPA | 3 : 5 : 1 | 8Ltr | 4-10kg/cm ² | 8kg/cm ² | 310LPG | Wire braided | 3.5Mtr | 6mm | 50/205 Ltr. | Trigger type |

MW250

Mig Welding Machine

MW250 is a semi-automatic MIG welding machine with IGBT controller and built-in wire-feeder. Suitable for welding of low carbon steel, low alloy steel, stainless steel, aluminium and its alloys.

Features

- Rugged design, reliable functioning and superior arc characteristics appropriate for both outdoor and indoor usage.
- Maximum reliable and dependable workhorse welding machines with low functioning cost.
- Instant release wire feed roller mechanism enables operator to change the wire spool instantly



| Technical Data | | | | |
|----------------|-----------------|-------------------|-------|------------|
| Code | Welding Current | Power Consumption | Phase | Cooling |
| MW250 | 250A | 17.5 kVA | 3 P | Forced Air |

SWP

Spot Welding Machine

Designed to spot weld different types of steel such as double-layer and multi-layer high-strength steel. Welding capacity : 1.0+1.5 mm

Features

- LCD display, can set welding function easily.
- Precision over current protection to ensure safety in usage.
- Single-sided and double-sided spot welding.
- Stepless current regulation.
- Overheating protection.
- Double-sided C-type gun with double-piston design allows 360 degree rotation in stable pressure.
- High quality spot welding machines with resistance welding of car equipment.



| Technical Data | | | | |
|----------------|--------------|----------------|-------------|--------------|
| Code | Air Pressure | Input Voltage | Input Power | Cable Length |
| SWP | 4-8kg | 380V 50Hz/60Hz | 60 KVA | 3mtr |

DPM

Dent Puller Machine

SKY-DPM, with its 4000 A maximum output current, is the ideal product for dent pulling and straightening of low thickness car body elements (hood, door, roof panel). The product is multi functional, which makes it a complete solution. Thanks to its low power consumption, it can work on a simple 230V power supply.

Features

- 32A Mains protection MCB.
- Pulling and Carbon Multifunction modes.
- High Insulation.
- 13V Output voltage.
- Application - Car Dent Puller
- Stainless Steel body material.



| Technical Data | | | | | |
|----------------|-----------------|----------------------|-------------|--------|-------------|
| Code | Welding Current | Degree of Protection | Input Power | Phase | Noise Level |
| DPM | 4000A | IP21 | 16 kVA | Single | 65dB |

SWP

Car Body Repair System

Introducing the Car Body Denting Tool Kit mounted on a trolley with multiple allied functions. Tools are mounted on slotted sheet vertical stand for quick identification.

Features

- Special pullers made of aluminium material.
- Vacuum suction gun for dry denting.
- The system comes with a spotter machine as standard accessory.
- Bosch electric sander for grinding all sharp edge and welding spots.
- Different type of pulling arrangement for different car profiles.



SWC

Spot Weld Cutter

Spot Weld Cutter is designed to remove the spot weld while leaving the main parent metal intact. The weld cutter has a pivoting arm that gives you access to all the spot welds on the vehicle.

Features

- Weight: 1.8 kg
- Length: 300 mm
- RPM: 700 (without load)
- Noise level: 80 dB(A)
- Spotle/Boron drill: 8-40 mm.
- Drill: 8/6-40 mm.
- 8-40 mm.
- 8/10-40 mm.



| Technical Data | | | | |
|----------------|-------------------|-------------------|-----------|-----------|
| Code | Compatible Drills | Max. Air Pressure | Chuck Max | Frequency |
| SWC | 8/10 mm | 6.4 bar | 8.0 mm | 1.95 m/s2 |

SWC

Infrared Paint Curing Lamp Car Detailing

Features

- Adjustable Screen fully automatic.
- Lamp Type - infrared curing lamp for car detailing and bodyshop.
- Usage/Application - Ceramic coating curing and paint curing.
- Light Source Type - LED
- Positioning - Floor Standing.
- Baking area - 1200x1000mm
- Tube life - 8000h
- Temperature measurement.
- Lamp body 360De turning, with automatic alarm ring.



| Technical Data | | | | |
|----------------|----------------|---------|---------|--------|
| Code | Temperature | Power | Height | Weight |
| SWC | 40 / 100 Deg C | 3x1100W | 18.5 Cm | 989 gm |

PP4/10T

Hydraulic Porta Power Auto Body Frame Repair Kit

Ideal for automotive, truck, farm and heavy equipment repair, auto body and frame repair

4Ton Model

- Heavy duty & high durability metal material
- with up to 4-Ton weight capacity. Easy to set up & easy to operate. Put them back to the case easily when not in use to save space. Leakless design makes the work more safe.
- more safe. The maximum lifting height is up to 120 mm, which will make your work conveniently

10Ton Model

- 4 Extension Included: 22", 12", 8", 4"
- Included: Jack Hose, 10 Ton Ram, Spreader Ram, Male Connector, Flat Base, 90 Degree "V" Base, Wedge Head, Spreader Plunger Toe, Spreader Ram Toe, Flex Head, Serrated Saddle
- Main Body: 10 Ton Hydraulic Hand Pump



DE-30

Dust Extractor with Hose Pipe

SKY-DE30 Possibility to work without dust bags and Less maintenance.

Features

- Cable storage - Simple and effective.
- High quality and long reach cable.
- Big wheels improves maneuverability on uneven floor surface.



| Technical Data | | | | |
|----------------|--------------------|-----------------|-------------|-------------|
| Code | Container Capacity | Vacuum Pressure | Voltage | Power Input |
| DE-30 | 30L | 250 m bar | 220V - 240V | 1200 W |

HVLP3

Stainless Steel Spray Gun

Features

- Lightweight Sleek Ergonomic Design.
- Symmetric & Durable Gravity Cup.
- Unique ACT (Air Circulation Technology) Air Cap.
- Maximum Transfer Efficiency With Minimum Wastage.

Areas of Application

- Automobiles
- Furniture
- Industries
- Textile
- Sports
- Infrastructure
- Art & Design



| Technical Data | | | | |
|----------------|-----------------|-------------|--------------|----------------|
| Code | Air Consumption | Nozzle Size | Cup Capacity | Air Inlet Size |
| HVLP3 | 12 - 13 (cfm) | 1.3 mm | 570 ml | 1/4" |

Spray and Bake Paint Booth

Civil Base / Metal Base

We offer Automotive Paint Booth that is designed in a way to ensure better working environment as protect against dust and waste gas. These Automotive Paint Booths are used at various automobile repairing shops.



Advantages

- Protect from dust and waste gas.
- Gives better working environment.
- Improving service degree.
- Ensuring health of workers.
- Total air exhaust.
- Brake free position.
- Circuit solution and circulation.
- Demonstrated design and economics at many significant body shops.
- The circulation inside the generator ensure high level of fuel efficiency.
- Outside sheet metal in with 3 surface coating galvanized finish.
- Fully insulated wall panels.

- Power** : 10.5KW, 3PH/50hz.
- Wallboard** : Fire retardant PPGI Puf panel, Thickness : 50mm
- Foundation System** : Full metal galvanized foundation, 300mm height flat steel
- Heating System** : Diesel burner with SS heat exchanger
- Light System** : 14 set of ceiling light
- Air flow** : Centrifugal fan with 5 HP electric motor of air flow 21000M²/h, 12600 CFM
- Control Panel** : Automatic control panel with spray switch, baking switch, emergency stop, timer, overload protection, single phase protection, MCB and temperature controller.

| Technical Data | | |
|------------------------|---------------------------|-----------------------|
| Outer Dimns. (LxWxH)mm | Internal Dimns. (LxWxH)mm | Entrance Door (WxH)mm |
| 7000x5200x3600 | 6900x3900x2750 | 3000x2500 |

Automotive Crash Repair System

Completely mobile, use it in the shop, parking lot, wherever pulls are needed.

Features

- 5-ton pulling system with 10 ton hydraulics.
- Full 360 degree swivel for side, front & rear pulling.
- Post swivels 90 degrees for extended reach.
- Multiple position set-ups allow for all kinds of pulls.
- Secure four point clamping system, more firm.
- Includes down-pull and up-pull attachment .
- No tie downs or anchor pots needed .
- Fast, easy one man set-up .
- Includes two hydraulic cylinder and foot pump.
- Four stands.
- Pull-up boom, length and height can be adjustable.
- High strength chain.
- 10T pull-up cylinder.
- Large capacity pneumatic hydraulic cylinder.



| Technical Data | | | | |
|----------------|-----------------------|-----------------|------------------|--------------|
| Weight | Max. Lifting Capacity | Worktable Width | Worktable Length | Bench Height |
| 800kg | 3.5T | 680mm | 3000mm | 225mm |

DDG6

Digital Depth Gauge



Metal Digital Depth Gauges with dual mode measurement system - inches & mm

Free wheeling thumb roller mechanism for smooth movement along the linear scale

Large high contrast LCD digital readout. Integral data output interface to transfer data to PC/ Laptop

| Technical Data | | |
|----------------|--------|----------|
| Code | Range | Accuracy |
| DDG6 | 150 mm | +/- 0.02 |

LED340

LED 60 SMD Rechargeable Work Light

Rugged unbreakable construction - ideal for use in machinery repair, testing, automotive jobs etc.

60 SMD produces a super bright work light (350 lumens)

Dual Voltage AC charger for use with 220V AC, 50 Hz / 110V AC, 60 Hz



Charge Time:
3 hours

| Technical Data | | | |
|----------------|-------|--------------|----------|
| Code | Lumen | Power Source | Run Time |
| LED340 | 350 | 220V AC | 3.5 H |

DCS200

Video Borescope Video Inspection System

Compact Video Borescopes for live Visual Inspection of inaccessible areas.

Probe is water, oil and dust proof



Color LCD Display with 300x240 resolution

Ideal for Plumbing, Electrical, Construction, DIY / Home owners, HVAC/R & Automotive / Fleet shops

| Technical Data | | | |
|----------------|---------------|--------------|------------|
| Code | Field of view | Probe Length | DOF |
| DCS200 | 60° | 1 Mtr. | 0.98-11.8" |

MNL300

Magnetic Nail Lifter

Used for quick Clearing of dangerous ferrous scrap metals which include iron chips, shavings, nails, nuts, screws, tacks, barbed wire and staples etc.

Wheels With Double Ball Bearing

Bottom Plate & Magnet



| Technical Data | | | |
|----------------|--------------|----------|---------------|
| Code | Magnet size | Material | Handle Length |
| MNL300 | 300x130x30mm | S.S. | 3Ft |

MW-01

Manual Wrench / Labor Saving Wrench

When your normal wrench is not able to do the job on some stuck lag nuts, you really need to ramp up your torque! Our torque multiplier set includes a high-grade set of handle and wrench attachments, as well as the protective carrying case.

The purpose here is to give extra leverage on tight bolts where a conventional tool is not going to give you the power you need to loosen them. Made from High-quality Alloy steel.



| Code | Ratio | Socket drive | Bar length | Weight |
|------|-------|--------------|------------|-----------|
| MW01 | 1:58 | 1 in | 10.6 in | 8kg (Net) |

DDG6

Mount/Demount Tubeless Tyre Kit for 19.5" to 24.5"

Mount all tubeless tyres range from 19.5"to 24.5", Demount tyre in 8 seconds, and remount in 20 seconds without strain. Demounting truck tyres with JM-100M so easily and won't damage beads. Two simple tools can do it all. Work on standard and super luxury beads.

| Code | Tool | Size | Weight |
|-------|------------------|------|--------|
| 100M | Demounting lever | | 10kg |
| 200M | Mounting lever | | 6kg |
| 40B | Impact Hammer | | 14kg |
| Bk50 | Bead holder | | 1kg |
| P1000 | Tyre paste | | 1kg |

TTL760

Tubeless Truck Tyre Lever For Drop Centre Rims-760mm

This is for removing tubeless truck tyres mounted on 15 degree drop-centre rims.

| Code | Length | Weight |
|--------|--------|---------|
| TTL760 | 760mm | 1.630kg |

Drop forged chrome Vanadium steel
Hardened & tempered for longer life, Black finish

TTL800

Tubeless Truck Tyre Lever For Drop Centre Rims-800mm

This is for removing tubeless truck tyres mounted on 15 degree drop-centre rims.

| Code | Length | Weight |
|--------|--------|---------|
| TTL800 | 800mm | 1.950kg |

Drop forged chrome Vanadium steel
Hardened & tempered for longer life, Black finish

TTL1270

Impact Bead Breaker

| Code | Length | Weight |
|---------|-------------|----------|
| TTL1270 | 1270-2030mm | 10.500kg |

Used to easily loosen beads of the tyre with bead-breaking foot and ram bar but never cuts the bead

TTL1050

Truck Lock Ring Removal Tool

| Code | Length | Weight |
|---------|--------|---------|
| TTL1050 | 1050mm | 3.500kg |

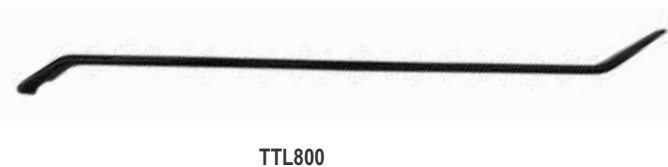
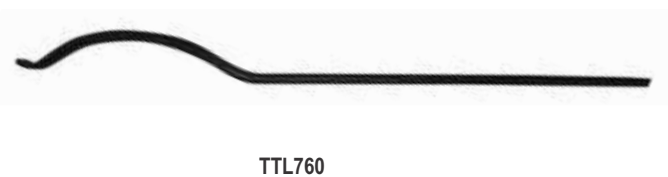
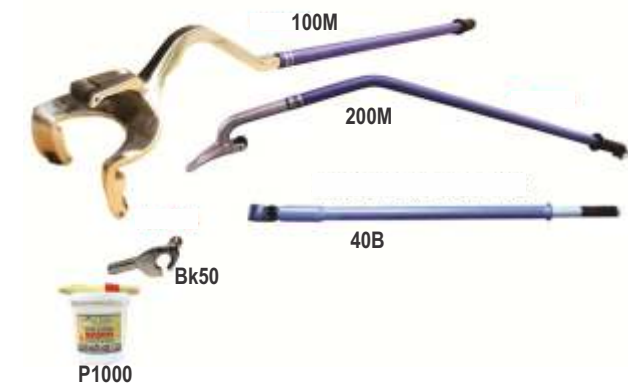

WD-01

Wheel Dolly Lift Car Vehicle Positioning Moving

These dollies allow you to lift the wheels off the ground and move cars around, whether they run, roll or not. Each of these hydraulic wheel dollies can lift up to 1250 lbs. and work with tires up to 12 in. W. Heavy-duty ball bearing casters allow cars to be easily maneuvered around most paved and concrete surfaces.



Features

- Material: steel
- Material of caster: nylon
- Lift type: foot pedal ratchet system
- Caster size: 3.5 in.
- Each weight capacity: 1,250 lbs.
- Perfect wheel dolly for most cars and light vans, you could just put it in the trunk and use it at anytime and anywhere for most vehicles
- Made from high-quality steel, this wheel dolly could easily hold wheels or vehicles and is not easy to be out of shape

Tyre Inflator

Digital Tyre Inflator

Tyre Inflator which marries the ruggedness of a metal analogue inflator with the lightness, accuracy and ease of use of a digital gauge

Extremely robust aluminium body with protective rubber bumper

3 units of calibration toggle as standard psi, bar & kPa.



Technical Data

| Code | Hose length | Valve connection | Calibration |
|---------------|-------------|------------------|-------------|
| DAC403 | 0.53 m | Twin Hold-on | 4-250 psi |
| DAC404 | 0.53 m | Single Clip-on | 4-250 psi |
| DAC405 | 1.8 m | Twin Clip-on | 4-250 psi |
| DAC408 | 0.53 m | Euro Clip-on | 4-250 psi |

Tyre Inflator

Digital Tyre Inflator

Lightweight - Gauge body weights 923g, less work strain and easier for repetitive use.

New Viewing Window - Larger window gives 20% greater field of viewing.

Biomorphic Shape - Ergonomic, easier to use and less prone to damage when dropped.



Technical Data

| Code | Hose length | Valve connection | Calibration |
|----------------|-------------|------------------|-------------|
| AFG4H03 | 0.53 m | Twin Hold-on | 0-138 psi |
| AFG4H04 | 0.53 m | Single Clip-on | 0-138 psi |
| AFG4H08 | 0.53 m | Euro Clip-on | 0-138 psi |
| AFG4H05 | 1.8 m | Twin Clip-on | 0-138 psi |

Tyre Inflator

Truck Tyre Inflator

Lightweight - Gauge body weights 923g, less work strain and easier for repetitive use.

New Viewing Window - Larger window gives 20% greater field of viewing.

Biomorphic Shape - Ergonomic, easier to use and less prone to damage when dropped.



Technical Data

| Code | Hose length | Valve connection | Calibration |
|----------------|-------------|------------------|-------------|
| AFG5H36 | 3.6 m | Twin Hold-on | 0-174 psi |

Tyre Inflator

Analog Tyre Inflator

This robust, lightweight, handheld mechanical tyre inflator offers fast. Trouble-free tyre inflation for tyreshops, garages, car dealers and transport depots.

Direct valve design increases inflation and deflation rates



Technical Data

| Code | Hose length | Valve connection | Calibration |
|-----------------|-------------|------------------|-------------|
| AFG1H03 | 0.53 m | Twin Hold-on | 0-170 psi |
| AFG1H06 | 2.7 m | Twin Clip-on | 0-170 psi |
| AFG1H08 | 1.8 m | Euro Clip-on | 0-170 psi |
| TI 0014C | 0.53 m | Euro Clip-on | 0-170 psi |

Tyre Inflator

Electronic Tyre Inflator

Electronic tyre inflator designed to break the mould of existing handheld tyre inflation, with leading electronics and sensor technology as well as patented software.

It offers fast, accurate and trouble-free tyre inflation and deflation.



Technical Data

| Code | Hose length | Valve connection | Calibration |
|------------------|-------------|------------------|-------------|
| DAC1A03 | 0.53 m | Twin Hold-on | 0-174 psi |
| DAC1A06 | 2.7 m | Twin Clip-on | 0-174 psi |
| DAC1A08 | 1.8 m | Euro Clip-on | 0-174 psi |
| DTI081 | 0.53 m | Euro Clip-on | 0-174 psi |
| DTI081THO | 0.53 m | Twin Clip-on | 0-174 psi |

Tyre Inflator

Blowgun Style Tyre Inflator

Blowgun Style Tyre Inflator is a general purpose tyre inflator with an all Alloy body with a rubber protected gauge.

Simple and easy to use, they are ideal for general low volume tyre inflation.



Technical Data

| Code | Hose length | Valve connection | Calibration |
|--------------|-------------|------------------|-------------|
| LTG01 | 0.4 m | Euro Clip-on | 0-174 psi |

DN 0101

64 Pcs. Tool Kit for Vehicle Mechanics



| Technical Data | |
|----------------------------------------------------|-----|
| Description | Pcs |
| Bi Hexagon Ring Spaner 6x7-30x32 mm | 12 |
| Double Open End Spanner 6x7-30x32 mm | 12 |
| Circlip Plier Internal Straight 175 mm | 1 |
| Circlip Plier External Straight 175 mm | 1 |
| Grip Locking Plier 250 mm | 1 |
| Side Cutting Plier 150 mm | 1 |
| Combination Plier 210 mm | 1 |
| Long Nose Plier 150 mm | 1 |
| Water Pump Plier 250 mm | 1 |
| Ball Pein Hammer 300 Gms | 1 |
| Plastic Hammer 30 FL | 1 |
| Flat Screw Drivers 5x150, 8x250 & 8x300 mm | 3 |
| Screw Driver Two in One 6x140 mm | 1 |
| T-Sockets 8, 10 & 12mm | 3 |
| 12.5 Square Drive Bi Hexagon Sockets 17 & 19 mm | 2 |
| Extension Bar 125 mm | 1 |
| Sliding T-Handle 300 mm | 1 |
| Allen Key 1.5 to 10 mm | 9 |
| Adjustable Wrench 300 mm | 1 |
| Half Round File with handle 250 mm | 1 |
| Flat File Bastard with handle 250 mm | 1 |
| Oil Can | 1 |
| Octagonal Chisel 200 mm | 1 |
| Measuring Tape | 1 |
| Wire Brush | 1 |
| Torch | 1 |
| Scissor | 1 |
| Locks | 1 |
| Tool Chest | 1 |
| Empty Tool Chest Weight 9 Kg. | - |

DN 0103

130 Pcs. Tool Kit for Garage Maintenance



| Technical Data | |
|----------------------------------------------------------------|-----|
| Description | Pcs |
| Bi Hexagon Ring Spaner 6x7-30x32 mm | 12 |
| Double Open End Spanner 6x7-30x32 mm | 12 |
| Circlip Plier Internal Straight 175 mm | 1 |
| Circlip Plier External Straight 175 mm | 1 |
| Grip Locking Plier 250 mm | 1 |
| Side Cutting Plier 150 mm | 1 |
| Combination Plier 210 mm | 1 |
| Long Nose Plier 150 mm | 1 |
| Water Pump Plier 250 mm | 1 |
| Adjustable Wrench 300 mm | 1 |
| Ball Pein Hammer 500 Gms | 1 |
| Flat Screw Drivers 6x200 & 10x300 mm | 2 |
| Two in One Screw Drivers 6x140 & 6x250 mm | 2 |
| 12.5 Square Drive Bi Hexagon Sockets 8-24, 26-28, 30, 32 mm | 22 |
| Reversible Ratchet | 1 |
| Extension Bar 125 & 250 mm | 2 |
| Sliding T-Handle 300 mm | 1 |
| Universal Joint 75 mm | 1 |
| Socket Set 1/4 Drive (46 Pcs) | 46 |
| Centre Punches 150mm | 1 |
| Flat Chisel 235mm | 1 |
| Soft Faced Plastic Hammer 30FL | 1 |
| Soft Faced Plastic Hammer 40FL | 1 |
| Sledge Hammer Fibreglass Handle 1 Kg | 1 |
| Flat File Bastard with Handle 250 mm | 1 |
| Half Round File with Handle 250 mm | 1 |
| Allen Key (Short Pattern) 1.5 to 10 mm | 9 |
| Oil Can | 1 |
| Torch | 1 |
| Wire Brush | 1 |
| Tool Box | 1 |

RAD-100

Refrigerated Air Dryer



| Technical Data | | | | |
|-----------------------------------|--------|--------|--------|---------|
| Capacity Cfm | Max 40 | Max 60 | Max 80 | Max 100 |
| Max. Working Pressure (KG/cm2) | 12-40 | 12-40 | 12-40 | 12-40 |
| Pressure Drop | 0.2 | 0.2 | 0.2 | 0.2 |
| Air Inlet Temp | 45 | 45 | 45 | 45 |
| Air Inlet/Outlet Connection (BSP) | 1/2" | 1/2" | 1/2" | 1 1/2" |
| Auto Drain Outlet (BSP) | 1/2" | 1/2" | 1/2" | 1/2" |
| Refrigerant | R134A | R134A | R134A | R134A |
| Power Supply | AC220V | AC220V | AC220V | AC220V |
| Power Consumption (kw) | 0.4 | 0.4 | 0.6 | 0.6 |
| Pressure Dew Point | 4 | 4 | 4 | 4 |
| Atmospheric Dew Point | (-)-22 | (-)-22 | (-)-22 | (-)-22 |
| Length (mm) | 420 | 500 | 500 | 600 |
| Height (mm) | 650 | 730 | 730 | 900 |
| Width (mm) | 550 | 560 | 560 | 750 |
| Weight (mm) | 55 | 100 | 110 | 140 |

Hydraulic Press

Hydraulic System

The compact Blocks eliminate the leakage chances & also reduces the hydraulic pipes. This low Noise hydraulic system is placed on the rear side of machine, on top between two side plates. Pressure relief valve is provided to safe guard the system and Machine from overload.

Cylinder

The cylinder bodies are precisely made from forged steel material duly bored and fine honed for long sealing life.

Frame Construction

Frame is fabricated from IS-2062 graded rolled steel plates table and cutting beam are deeply reinforced & fines machines after stress relieving.

Standard Equipment

- Front Operator Control Box
- Operation & Maintenance Manual

Optional Equipment

- Die and Punch Tooling
- Anti-vibration mount
- Base Plate



| Technical Data | | | | | | |
|----------------|----------------------------------|-----------------|----------------------|-----------------------|----|---------------|
| Code | Distance between two column (mm) | Bed to ram (mm) | Stroke hand operated | Stroke power operated | HP | Rod size (mm) |
| SHP-15T | 750x200 | 125 | 100 | 200 | 2 | 55 |
| SHP-25T | 800x250 | 150 | 125 | 200 | 2 | 65 |
| SHP-40T | 950x350 | 175 | 150 | 250 | 2 | 85 |
| SHP-60T | 1000x400 | 175 | 150 | 250 | 3 | 100 |
| SHP-100T | 1200x600 | 175 | 150 | 300 | 3 | 125 |

BSR-801

Brake Shoe Riveting Machine

Brake Line Riveting Machine for Medium and Heavy Commercial Vehicles.

Operation : Pneumatic foot switch for easy operation

Riveting & De riveting of brake lining

Rivets : Aluminium/Copper/Brass

Rivet Size : 3mm to 12 mm

Heavy duty cylinder

4 sets of riveting / deriveting tools



| Technical Data | |
|---------------------|-----------------|
| Code | BSR-801 |
| Operating Type | Hydro Pneumatic |
| Rivet Dia. Capacity | 3 - 12 mm |
| Working Pressure | 6 -8 bar |
| Max. Punch Force | 5000 kg |
| Ma. Punch Stroke | 40 mm |
| Overall Sizes | 350x500x1550 mm |
| Approx. Weight | 160 kg |

Mobile Service Van

Mobile Service Van gives the convenience of a repair team coming and repairing the equipment at the site itself. This creates an increased level of convenience and time saving that helps relieve the major stress involved with maintaining a fleet of equipment and scheduling the preventive and conditional maintenance.

Benefits of Service Van

Taking care of the equipment fleet is directly taking care of the business.

Equipment breakdowns are deemed to occur at any given time and this leads to a loss in productivity and unnecessary downtime.

Also, preventive maintenance is the best way to keep the equipment safe and operational.

Cost Saving

The shifting of the equipment to the main workshop for repairs or servicing may not be viable due to logistics, time and money constraints and for this reason, we conceptualized Mobile Service Van.



List Of Equipments Installed In Mobile Service Van

- Hydraulic Scissor Lift With Dual Acting cylinder & Hydraulic Power Pack
- Locking Mechanism
- Lifting Arms & Rubber Pad
- Spare Parts Rack
- Water Tank Capacity 60 Ltr
- Waste Oil Collection pan 8 Ltr
- Air Compressor 2 HP Motor
- Service Creeper Cum Sitting Stool
- First Aid Box With Hanging Provision
- Battery Jumper Cable
- General Tools Set With Portable Tool Box
- Spark Plug Cleaner
- Portable Tyre Pressure Gauge
- Folding Table With Umbrella
- Genset 3 KVA
- Wheel Balancer

AVAILABLE MODELS

Alignment
Center
on Wheel

Washing
Center on
Wheel

Mobile
Service
Center on
Wheel



Why You Need?

- **Convenience** - Unparalleled convenience is the primary benefit of using a Mobile Van. There's no need to drive all the way across town to a shop.
- **Fast and efficient service** - Because traditional shops work on many vehicles at a time, your customer usually have to "get in line" and wait your turn for service. With a mobile service van, however, you give immediate, one-on-one attention to your customer.
- **One-on-one service** - Your customer get one-on-one service from a dedicated certified technician.
- **Quality work** - Whether your customer need an oil change, diagnostic, brake pads, tyre change, repair flat tyre or something more complicated, your customer can expect the same great service all around.

Wheel Alignment Machine Accessories



SW1011



BP1111



TT4004



WC4005



WC3004



992244



882222



77001



660001



993344



880022



880021



770001

Wheel Balancing Machine Accessories



P11004



C22001



C33001SET



QRN44001



S55001SET



SW6610G-SW66100G



SW77004

Tyre Changing Machine Accessories



TC110028



TC110030



TC22010



TC22020



TC33010



TC33015SET



TC33040SET



RF SWITCH



TC44040



AIR2210



BRAKE PEDAL ASSEMBLY

OUR DEALERS

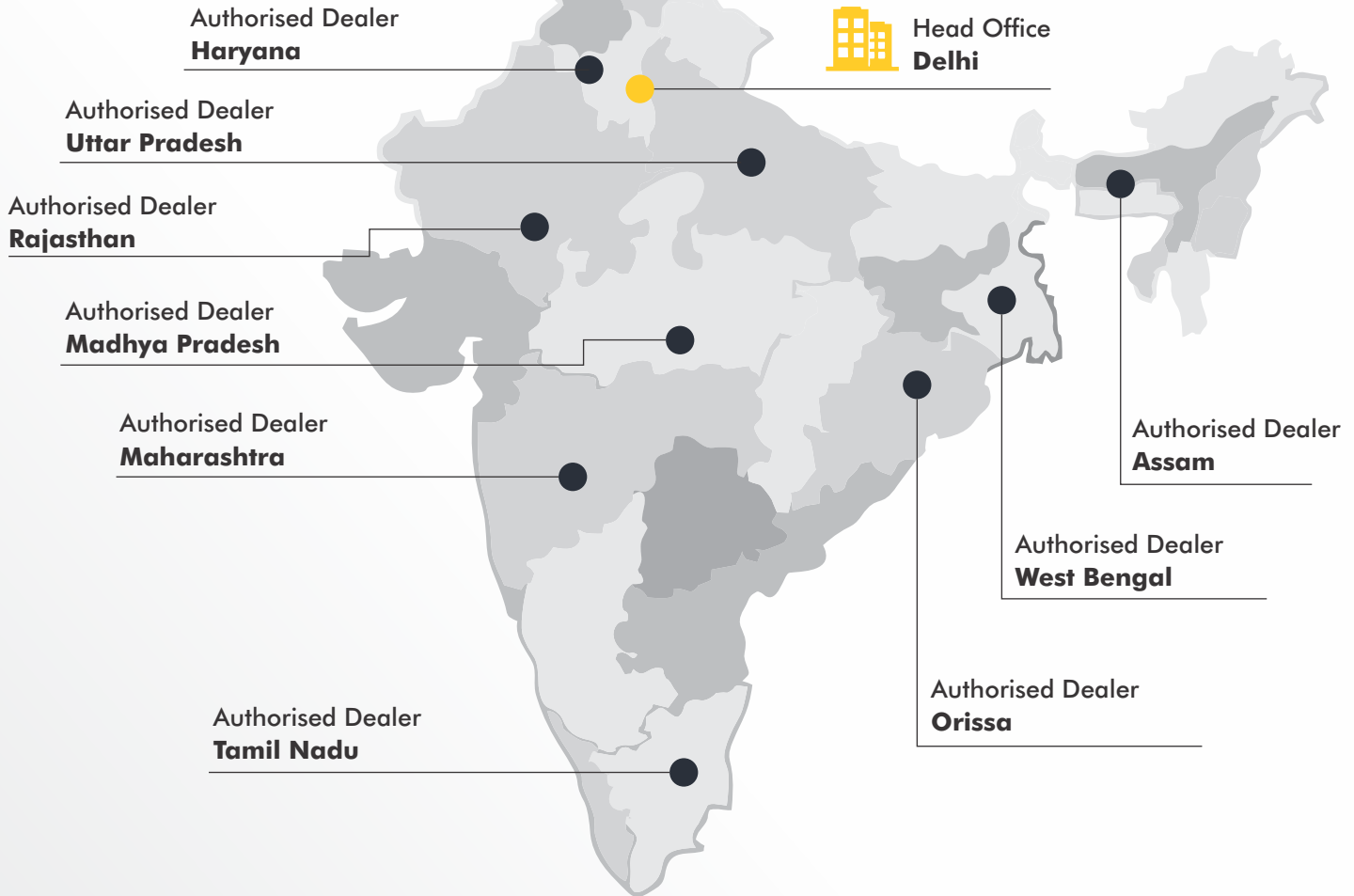

SKYTECH AUTOEQUIP CO.

Office : A-40 Jain Nagar Extn. Karala, Delhi-110081,
Opp. MLS Cygnus Hospital
Mobile : +91 844 725 8232, +91 971 793 0655
Website : www.skytechautoequip.com
eMail : sales@skytechautoequip.com | info@skytechautoequip.com

Follow us on



V-Card

For Sales Inquiry
sales@skytechautoequip.com

For Service Inquiry
service@skytechautoequip.com

Complain Number
+91 844 725 8232